

Sliding Gate Motor

Instructions and warnings for installation and use

1

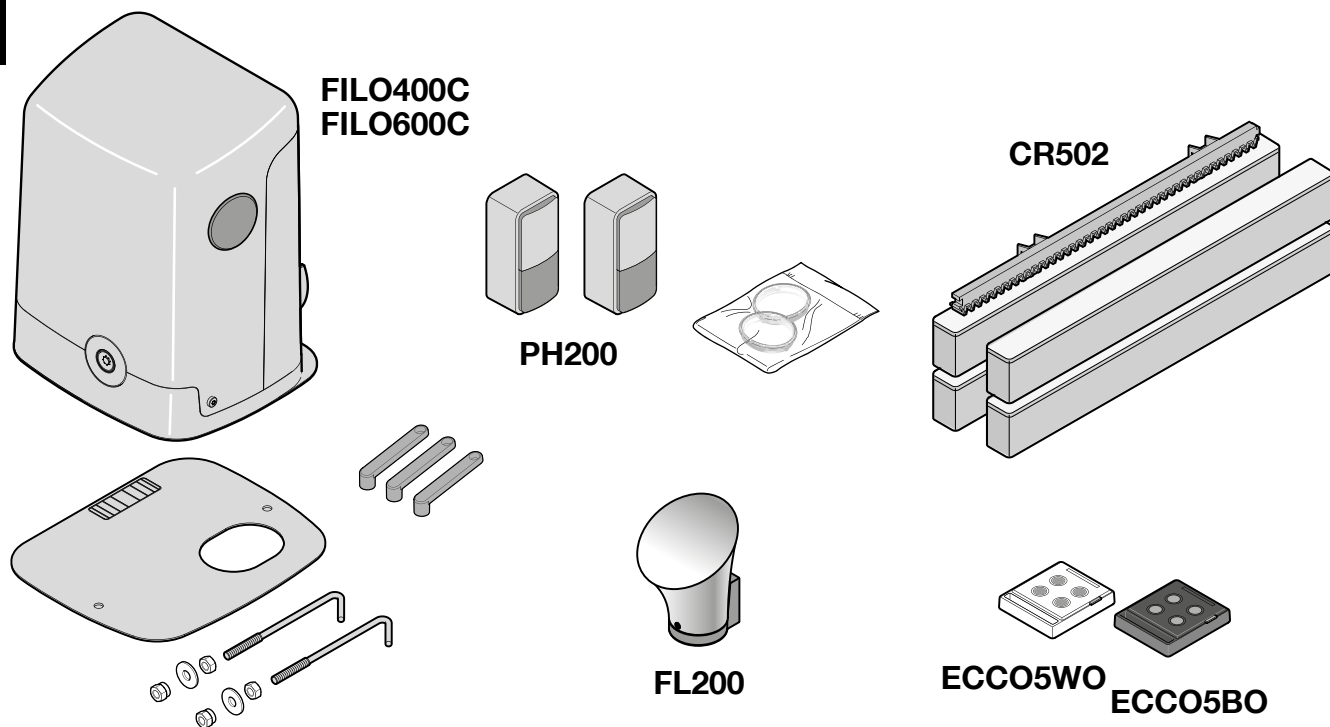

KIT FILO400	
FILO400C	n° 1 FILO400C
FL200	n° 1 FL200
PH200	un paio PH200
ECCO5WO	n° 1 ECCO5WO
ECCO5BO	n° 1 ECCO5BO
CR502	n° 4 CR502
KIT FILO400START	
FILO400C	n° 1 FILO400C
ECCO5BO	n° 1 ECCO5BO
KIT FILO600	
FILO600C	n° 1 FILO600C
FL200	n° 1 FL200
PH200	un paio PH200
ECCO5WO	n° 1 ECCO5WO
ECCO5BO	n° 1 ECCO5BO
CR502	n° 4 CR502
KIT FILO600START	
FILO600C	n° 1 FILO600C
ECCO5BO	n° 1 ECCO5BO

• The optional accessories not included in the package can be viewed on the following website: www.niceforyou.com

The pages below describe with images the main phases (divided into steps) to create the desired system:
Step A = observe → Step B = install → Step C = connect → Step D = initial start-up of the system carried out by a qualified electrician → Step E = programme.

Step A

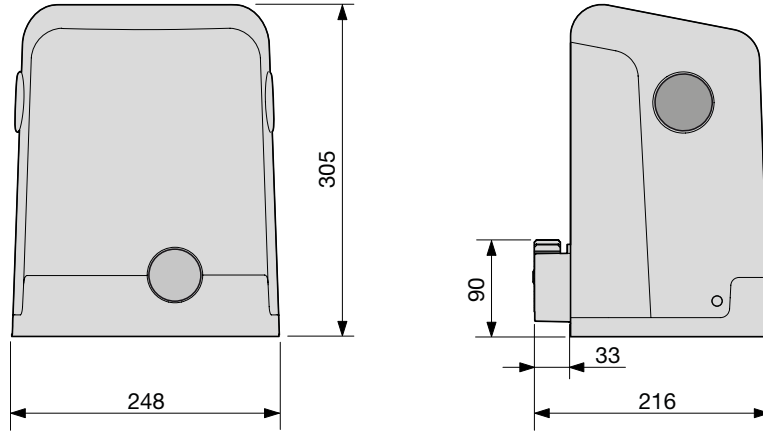

2

3

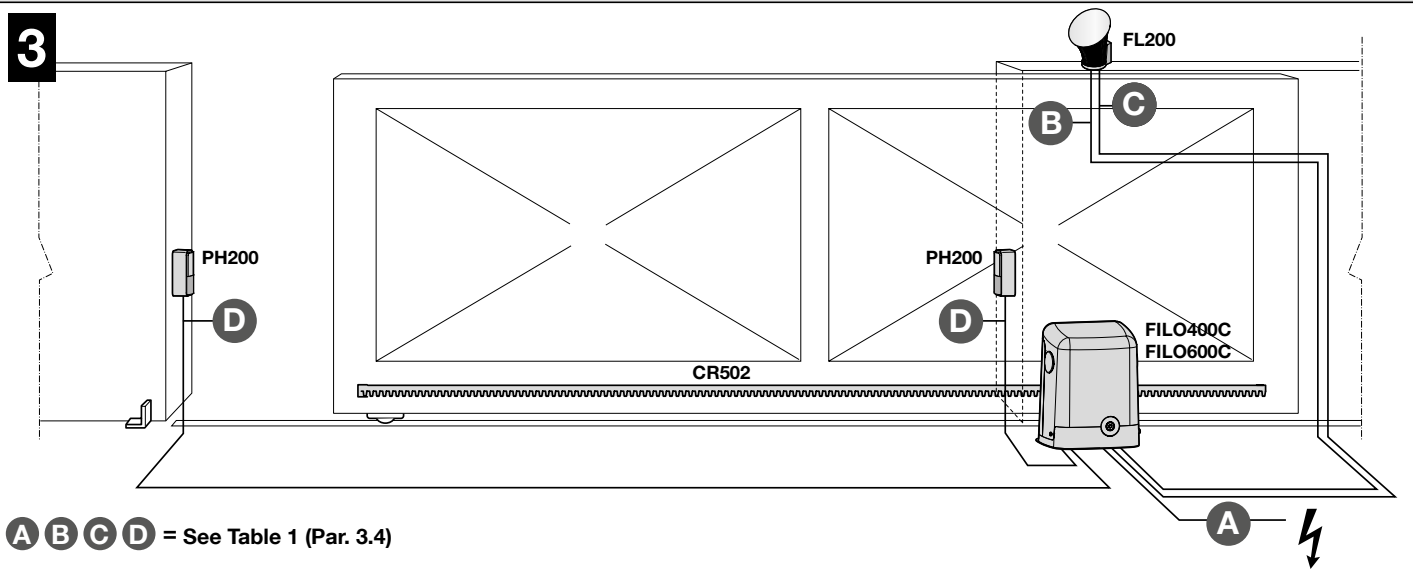

A B C D = See Table 1 (Par. 3.4)

Step B



Installation with rack to be mounted: see Fig. 4 (Par. 3.5.1) for the relevant procedure

Installation with existing rack: see Fig. 5 (Par. 3.5.2) for the relevant procedure

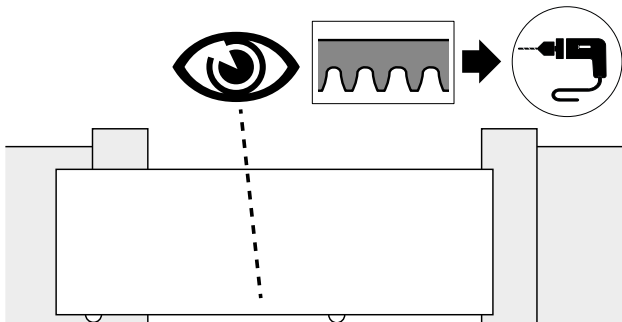

4

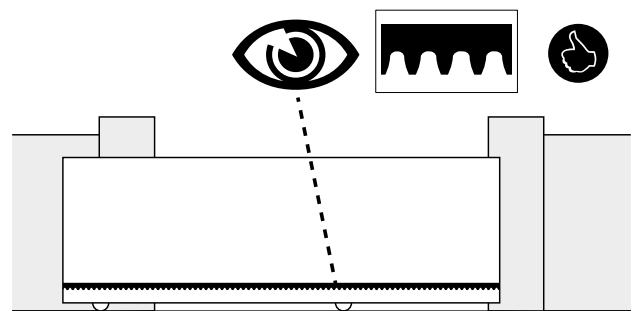

5

4

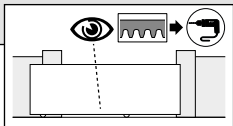

01.

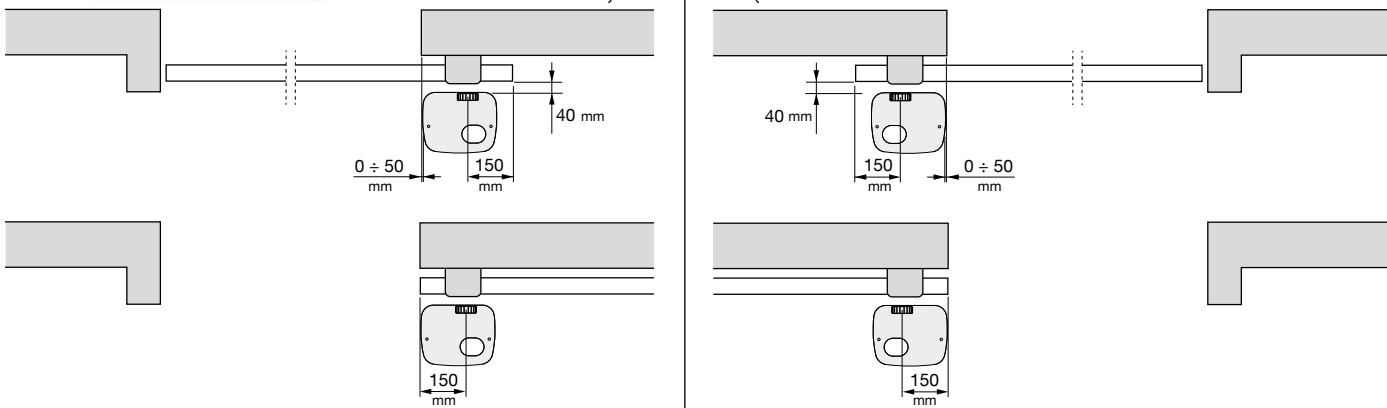

02.

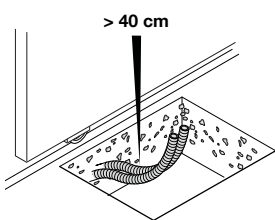

03.

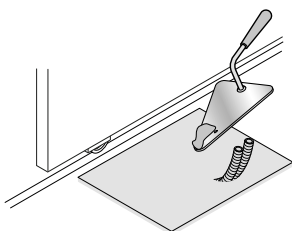

04.

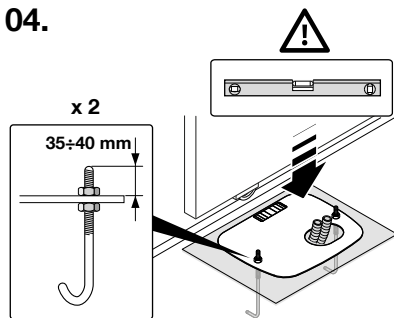

05.



06.

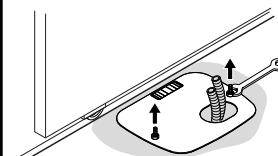

07.

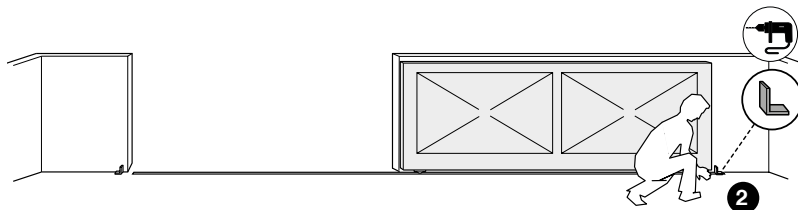
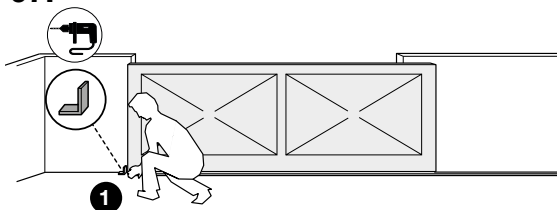

08.

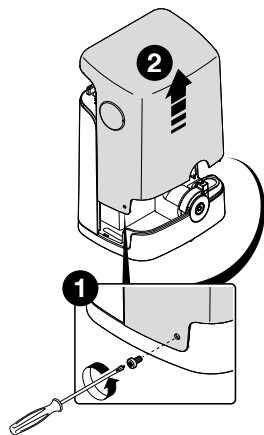

09.

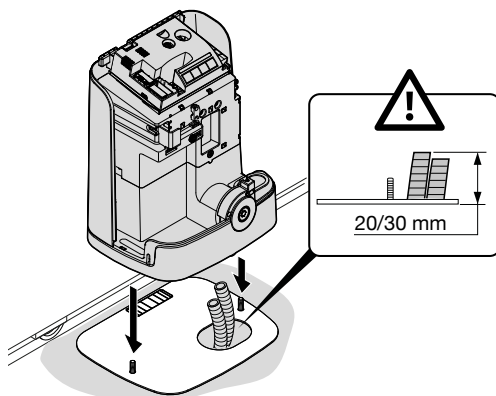

10.

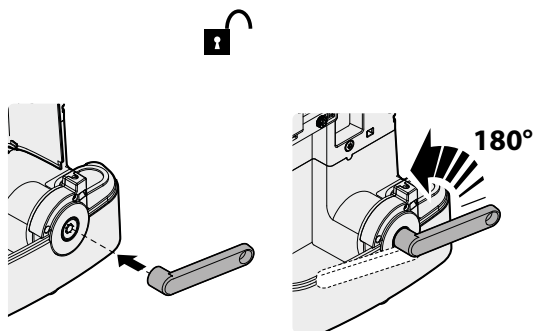

11.

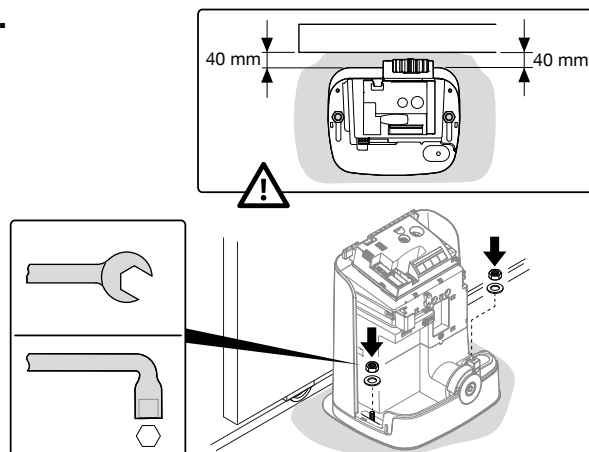



12.

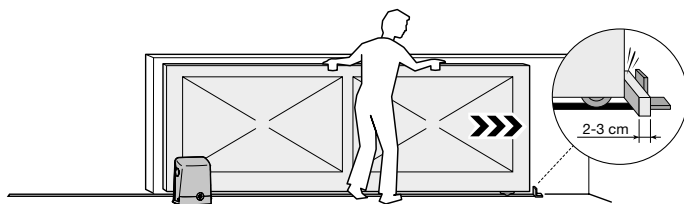

13.

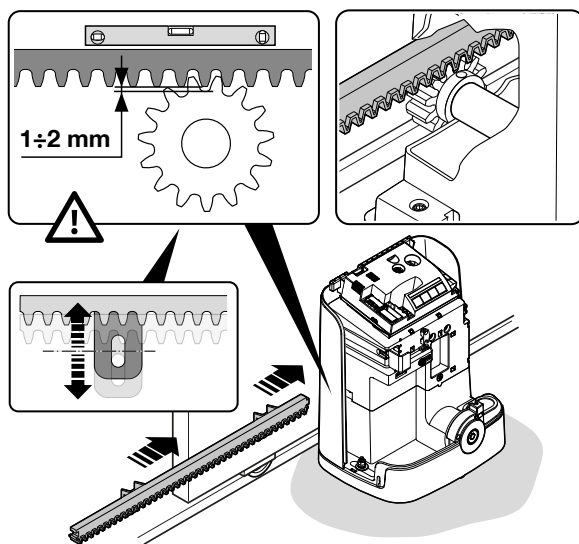

14.

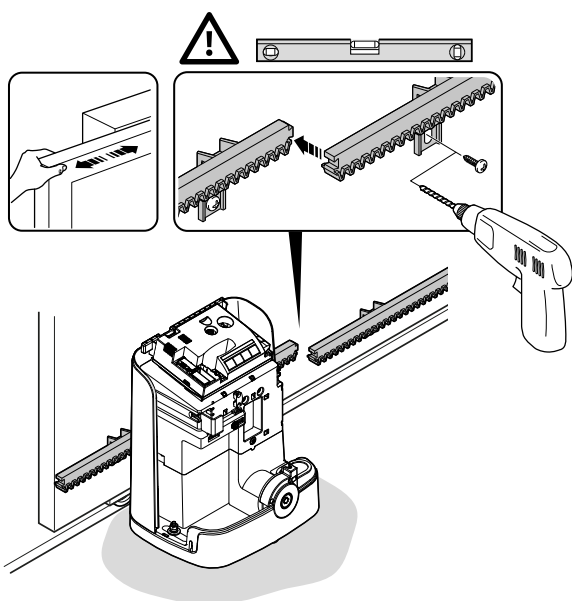

15.

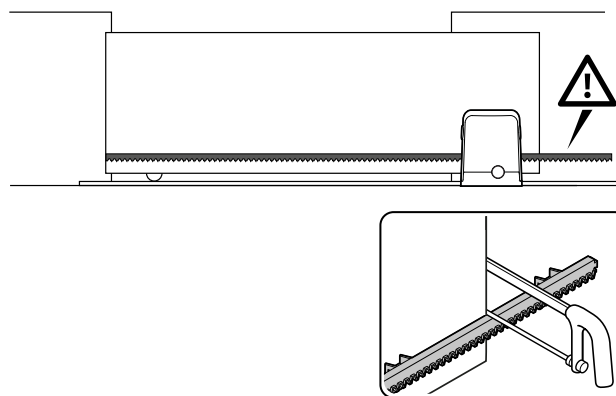

16.

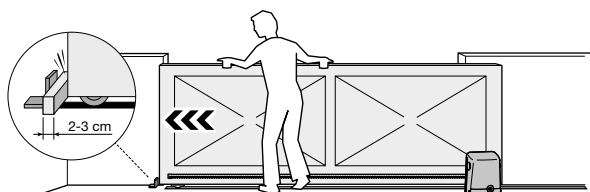

17.

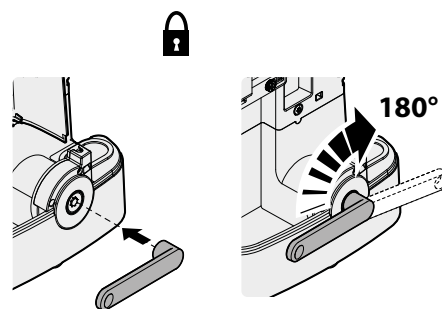

Installation of photocells > Fig. 6 - Paragraph 3.6



Installation of photocells > Fig. 7 - Paragraph 3.7

5

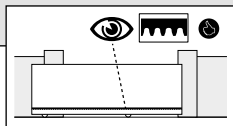

01.

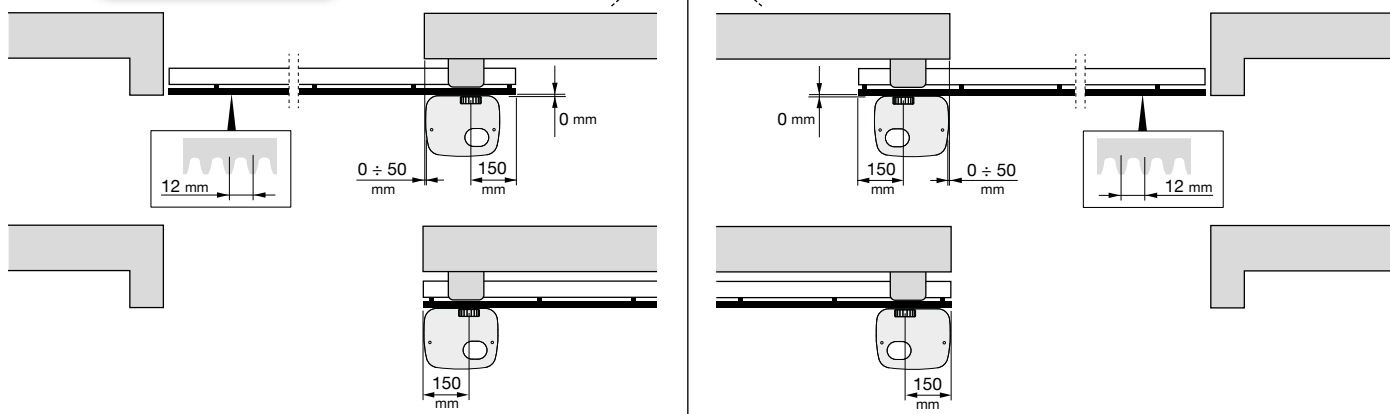

02.

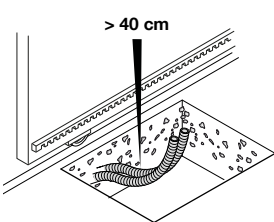

03.

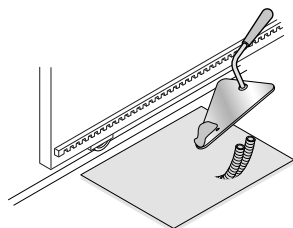

04.

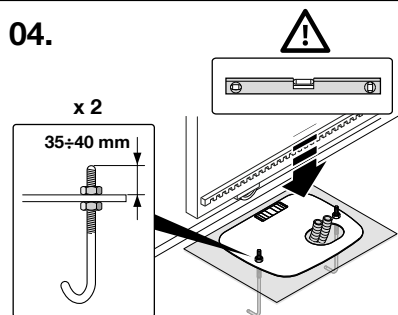

05.



06.

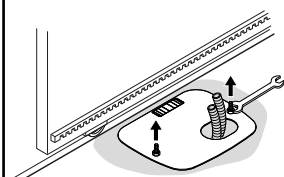

07.

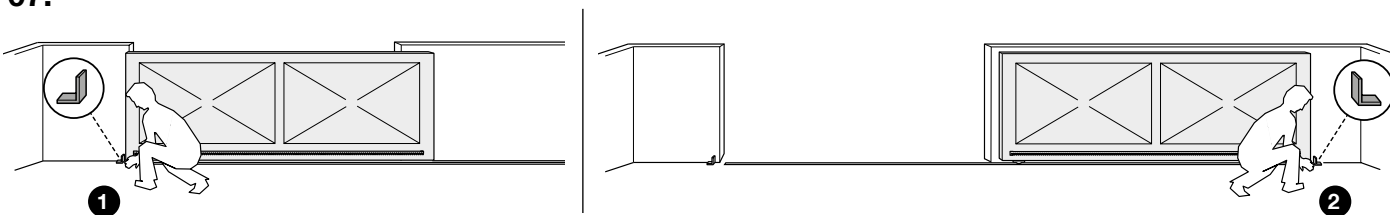

08.

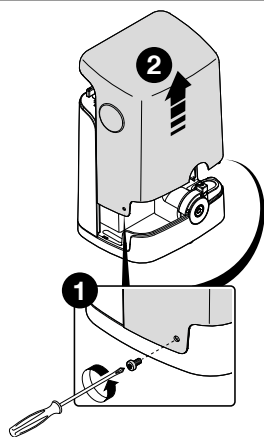

09.

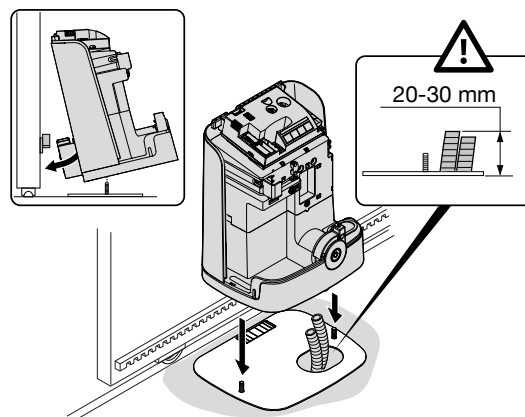

10.

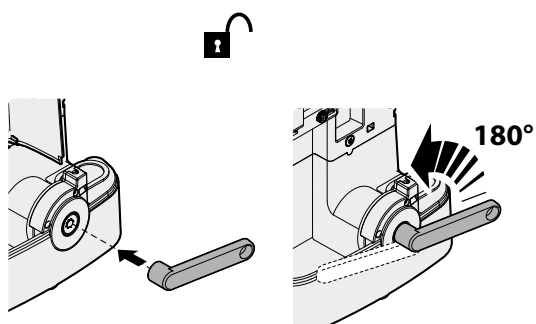

11.

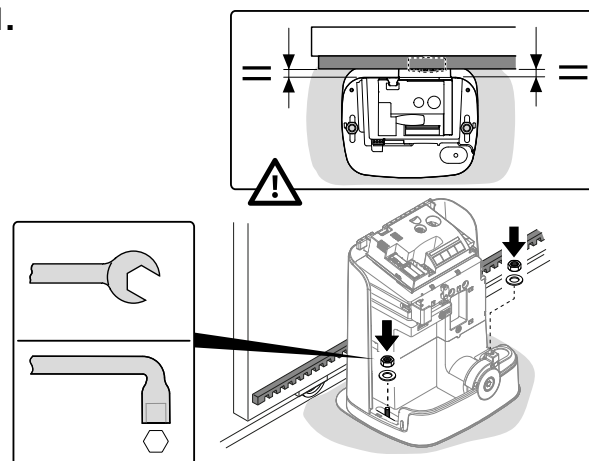

12.

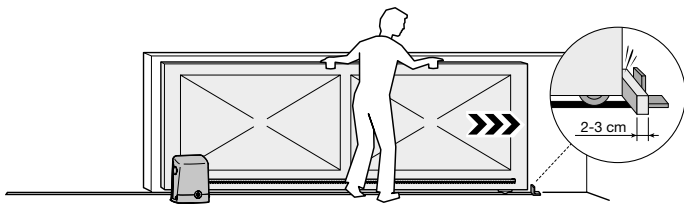

13.

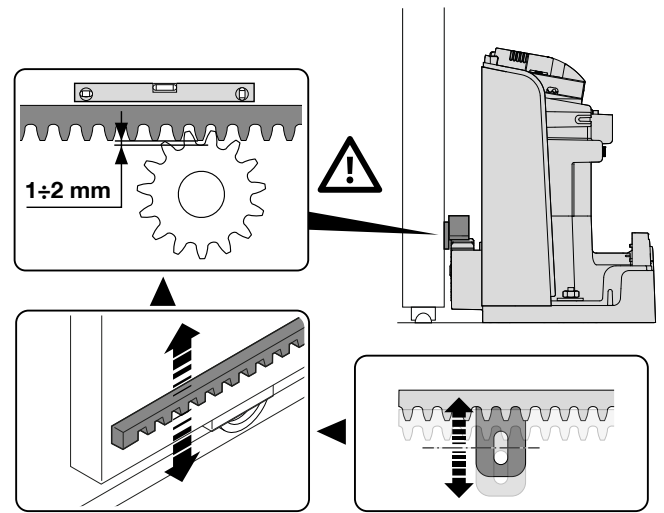

14.

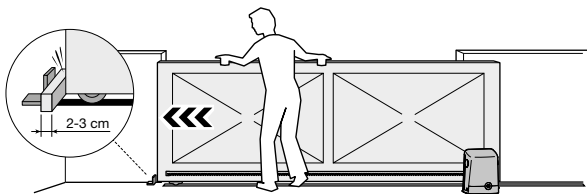

15.

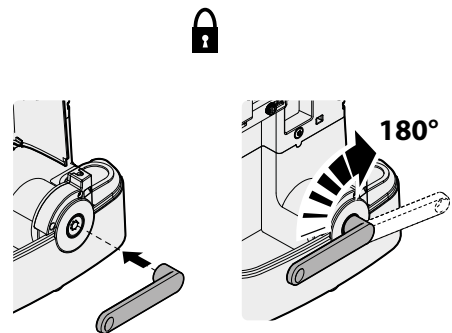

PH200

Installation of photocells > Fig. 6 - Paragraph 3.6



FL200

Installation of photocells > Fig. 7 - Paragraph 3.7

6a



PH200

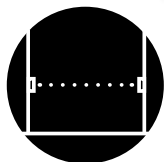

01.

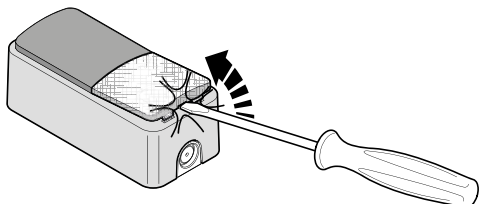

02.

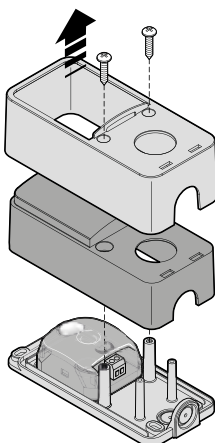

03.

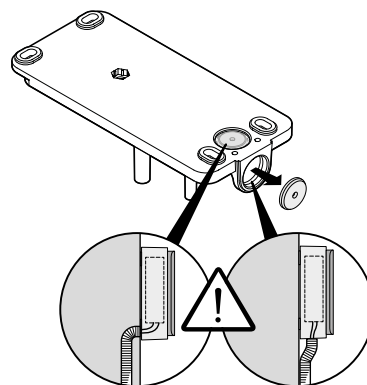

04.

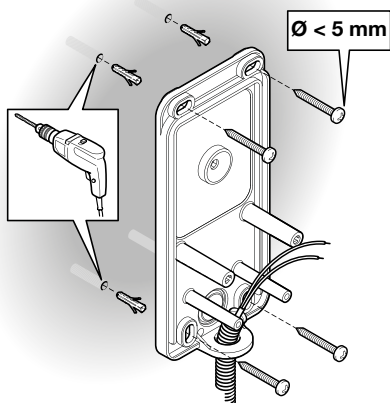

05.

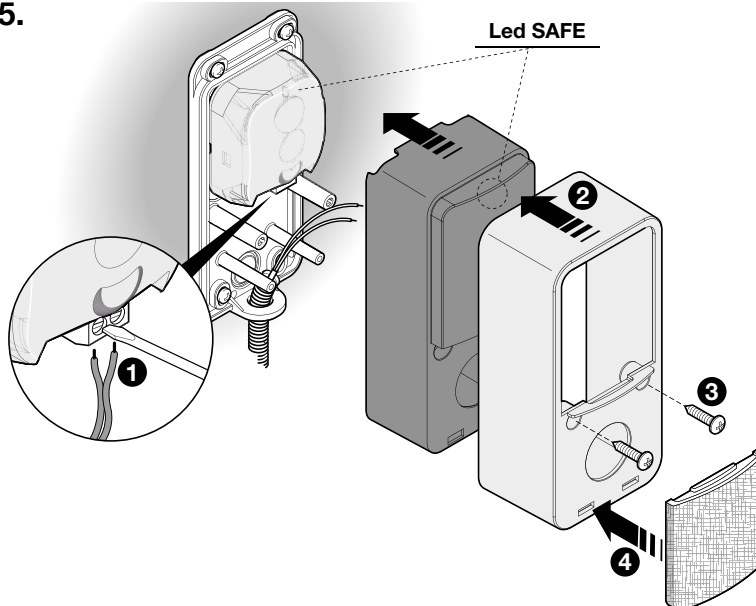

6b

01.

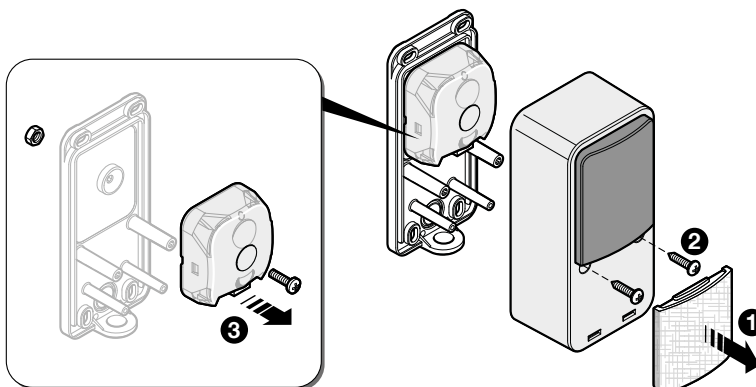
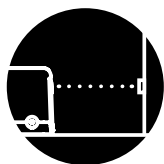

02.

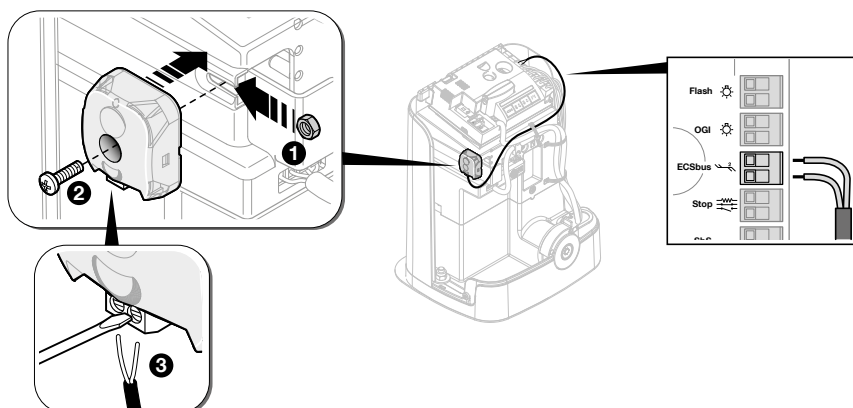

7



FL200

01.

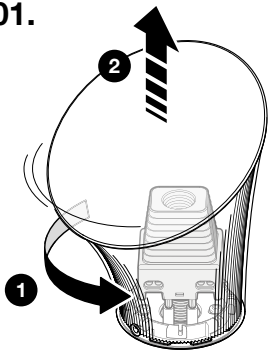

02.

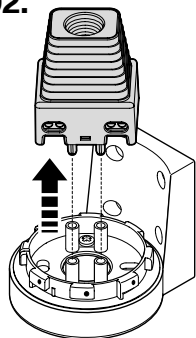

03.

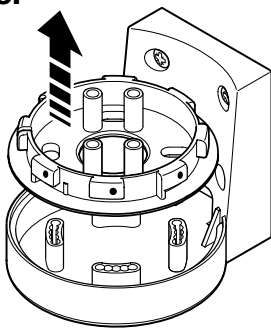

04.

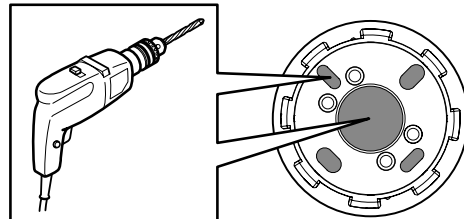

05. A

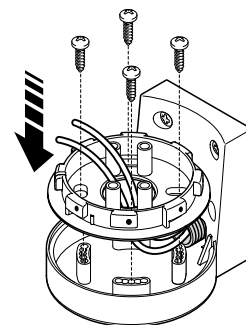
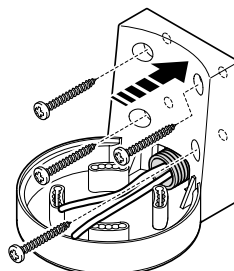
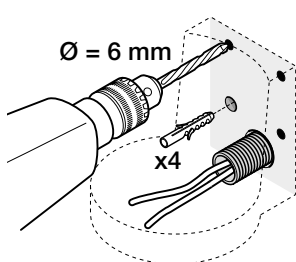
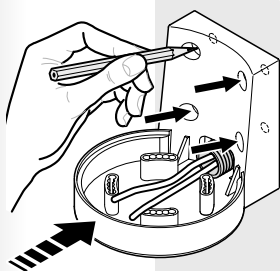
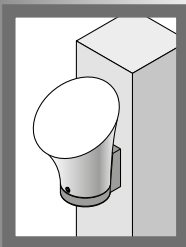

05. B

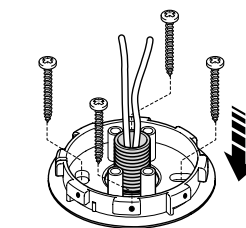
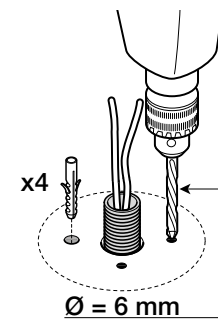
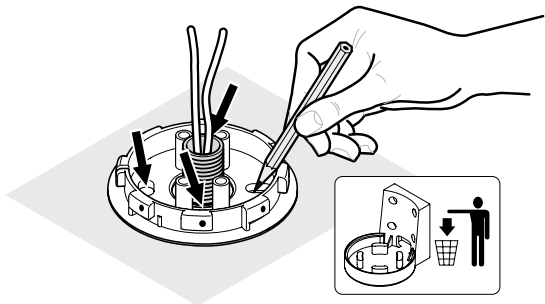
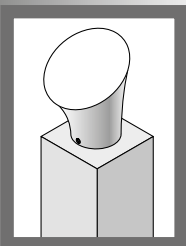

06.

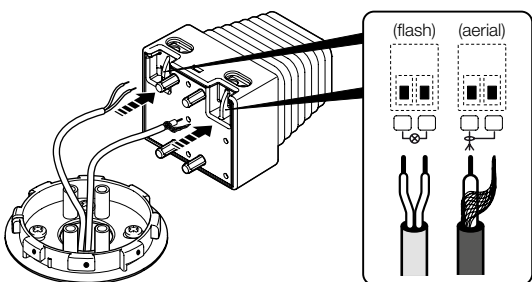

07.

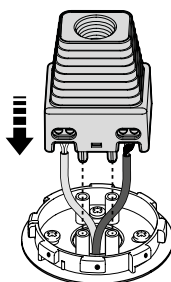

08.

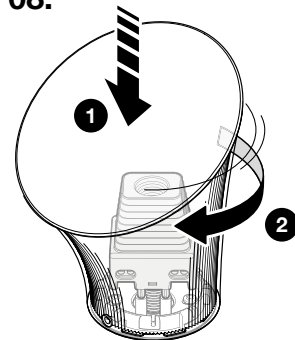

09.

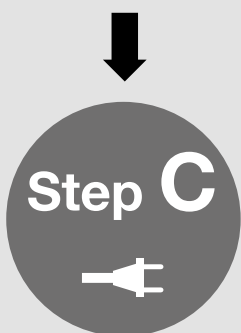
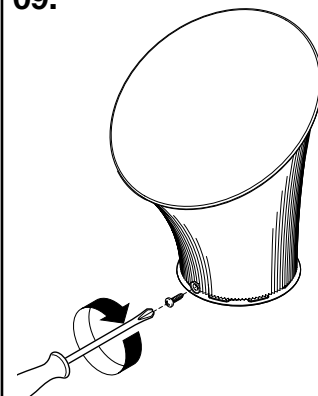

Step C

8

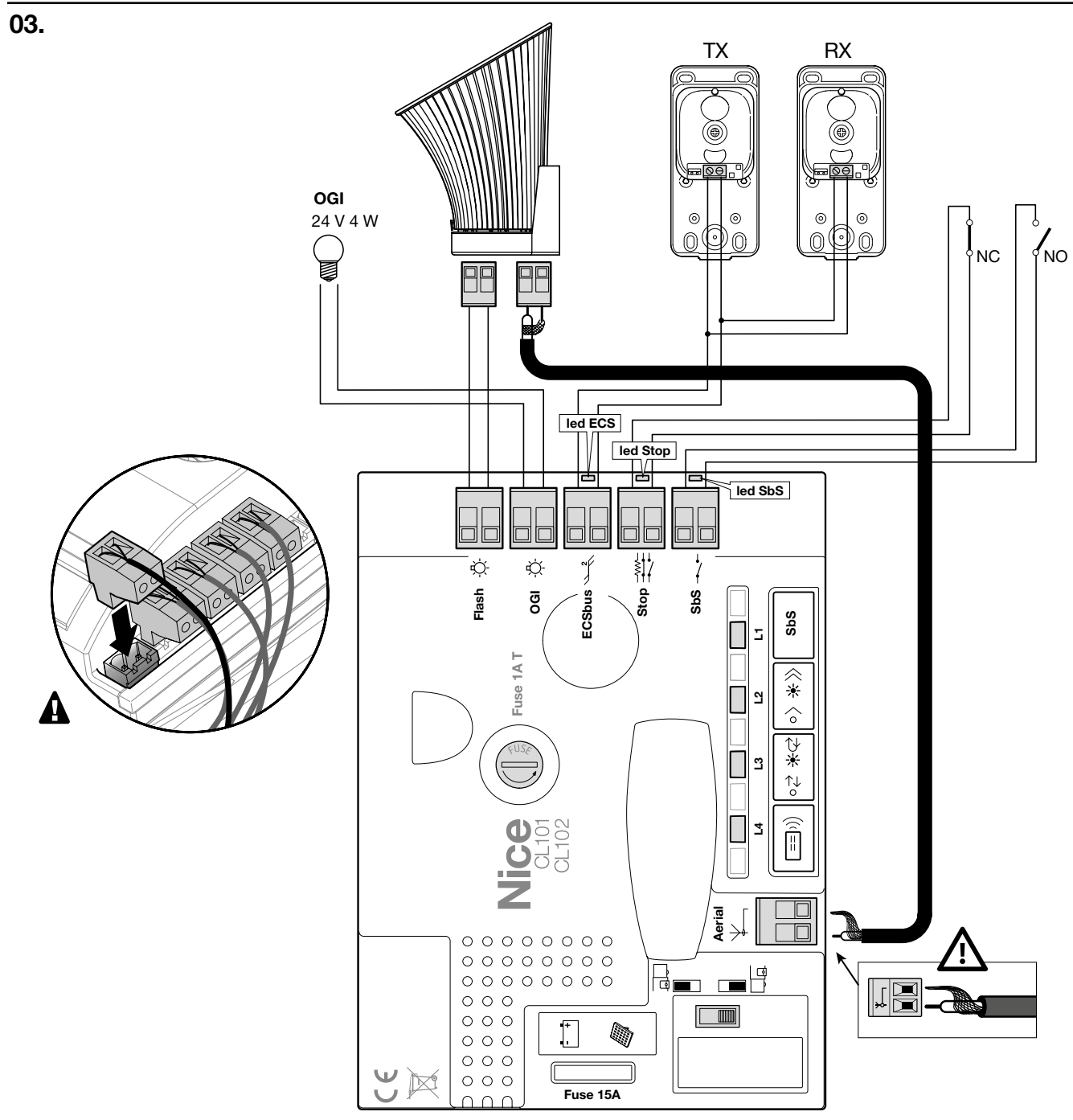
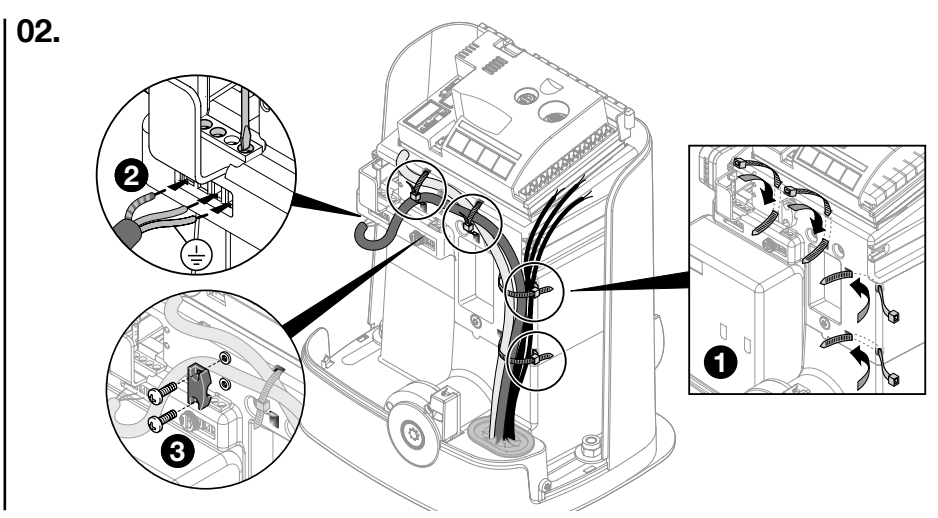
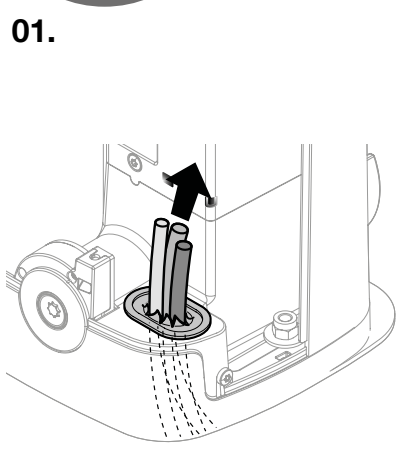

After having connected all the components of the kit and before closing the cover of the gear motor (Fig. 9), it is possible to connect other components designed for the system (optional and not present in the package).

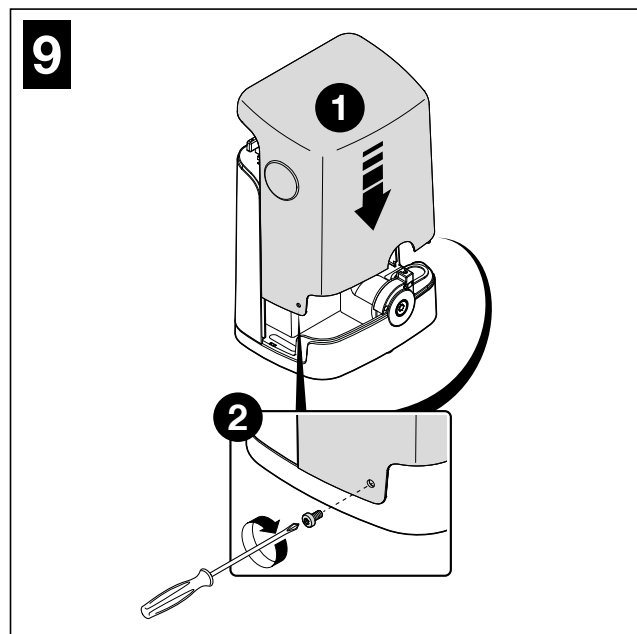

To start-up the system, see Chapter 5.



To PROGRAMME the system, see Chapter 6.

CONTENTS

QUICK GUIDE (images only)	I-XI
1 GENERAL WARNINGS: SAFETY - INSTALLATION - USE	1
2 PRODUCT DESCRIPTION AND INTENDED USE	2
3 INSTALLATION	2
3.1 VERIFYING THE SUITABILITY OF THE GATE AND ENVIRONMENT	2
3.2 VERIFYING THE PRODUCT'S APPLICATION LIMITS	2
3.3 PRODUCT TECHNICAL SPECIFICATIONS	2
3.4 PRE-INSTALLATION WORKS	3
3.5 INSTALLING THE FILO GEARMOTOR (model 400C/600C)	4
3.5.1 INSTALLATION WITH RACK TO BE MOUNTED	4
3.5.2 INSTALLATION WITH EXISTING RACK	5
3.6 INSTALLING THE PHOTOCELLS model PH200	5
3.7 INSTALLING THE FLASHING LIGHT model FL200	5
4 ELECTRICAL CONNECTIONS	5
4.1 ELECTRICAL CONNECTION TO THE CONTROL PANEL	5
4.2 POWER SUPPLY CONNECTION	5
5 PROGRAMMING	6
5.1 CONTROL UNIT KEYS	6
5.2 INITIAL CHECKS	6
5.3 MEMORISATION OF CONNECTED DEVICES	6
5.4 MEMORISATION OF THE GATE LEAF LENGTH (opening and closing)	7
5.5 MEMORISATION OF THE 1 ST TRANSMITTER	7
5.6 BASIC ADJUSTMENTS	8
5.6.1 Choosing the gate manoeuvre speed	8
5.6.2 Choosing the gate manoeuvre operating cycle	8
6 TESTING AND COMMISSIONING	8
6.1 TESTING	8
6.2 COMMISSIONING	9
7 MAINTENANCE	9
8 PRODUCT DISPOSAL	9
9 FURTHER INFORMATION	9
9.1 ADVANCED ADJUSTMENTS	10
9.1.1 Adjusting the parameters using the transmitter	10
9.1.2 Presence function	10
9.1.3 Verifying the values set for each parameter using the transmitter	10
9.2 ADDING OR REMOVING DEVICES	10
9.2.1 Memorising additional devices	10
9.3 MEMORISING ADDITIONAL TRANSMITTERS	11
9.3.1 Mode 1 memorisation procedure	11
9.3.2 Mode 2 memorisation procedure	11
9.3.3 Memorisation procedure near the control unit with two transmitters	11
9.4 DELETING THE MEMORY OF THE INDIVIDUAL TRANSMITTER FROM THE CONTROL UNIT'S MEMORY	12
9.5 COMPLETE DELETION OF THE RADIO MEMORY	12
9.6 INSTALLING THE BACK-UP BATTERY	12
9.7 INSTALLING THE SOLAR POWER SYSTEM KIT model SOLEKIT	12
9.8 230 V LIGHT OUTPUT CONNECTION	13
9.9 INSTALLING THE EXTERNAL RELEASE SYSTEM model KS200KIT	13
9.10 DIAGNOSTICS AND DEVICE SIGNALS	13
9.10.1 Photocell signals	13
9.10.2 Flashing light signals	14
9.10.3 Control unit signals	14
9.11 SPECIFICATIONS	15
9.11.1 ECSEBus system	15
9.11.2 Stop input	15
9.11.3 Product durability	15
10 TROUBLESHOOTING	16
11 USER GUIDE (to be delivered to the end user) (detachable insert)	A
ANNEX I (detachable insert)	B
EC Declaration of Conformity	01

1 GENERAL WARNINGS: SAFETY - INSTALLATION - USE (original instructions in Italian)

CAUTION Important safety instructions. Observe all the instructions as improper installation may cause serious damage

CAUTION Important safety instructions. It is important to comply with these instructions to ensure personal safety. Store these instructions

- Before commencing the installation, check the "Product technical specifications", in particular whether this product is suitable for automating your guided part. Should it be unsuitable, DO NOT proceed with the installation
- The product cannot be used before it has been commissioned as specified in the "Testing and commissioning" chapter

CAUTION According to the most recent European legislation, the implementation of an automation system must comply with the harmonised standards set forth in the Machinery Directive in force, which allow for declaring the presumed conformity of the automation. On account of this, all operations regarding connection to the mains electricity, as well as product testing, commissioning and maintenance, must be performed exclusively by a qualified and skilled technician!

- Before proceeding with the product's installation, check that all materials are in good working order and are suitable for the intended applications
- The product is not intended for use by persons (including children) with reduced physical, sensory or mental capacities, nor by anyone lacking sufficient experience or familiarity with the product
- Children must not play with the appliance
- Do not allow children to play with the control devices of the product. Keep the remote controls out of reach of children

CAUTION In order to avoid any danger from inadvertent resetting of the thermal cut-off device, this appliance must not be powered through an external switching device, such as a timer, or connected to a supply that is regularly powered or switched off by the circuit

- Provide a disconnection device (not supplied) in the plant's mains power supply, with a contact opening distance that ensures complete disconnection under the conditions envisaged by Overvoltage Category III
- Handle the product with care during installation, taking care to avoid crushing, knocks, falls or contact with liquids of any kind. Keep the product away from sources of heat and open flames. Failure to observe the above can damage the product and increase the risk of danger or malfunctions. If this should happen, stop installation immediately and contact the Customer Service
- The manufacturer assumes no liability for damage to property, items or persons resulting from non-compliance with the assembly instructions. In such cases the warranty does not cover material defects
- The weighted sound pressure level of the emission A is lower than 70 dB(A)
- Cleaning and maintenance to be carried out by the user must not be effected by unsupervised children
- Before intervening on the system (maintenance, cleaning), always disconnect the product from the mains power supply
- Check the system periodically, in particular all cables, springs and supports to detect possible imbalances, signs of wear or damage. Do not use if repairs or adjustments are necessary, because a failure with the installation or an incorrectly balanced automated system may lead to injury
- The packaging materials of the product must be disposed of in compliance with local regulations
- Keep persons away from the gate when it is moved through the control elements
- When performing a manoeuvre, keep an eye on the automated mechanism and keep all bystanders at a safe distance until the movement has been completed
- Do not operate the automation if anyone is working on it; disconnect the power supply before permitting any work to be carried out

INSTALLATION PRECAUTIONS

- Prior to installing the drive motor, check that all mechanical components are in good working order and properly balanced, and that the automation moves correctly
- If the gate being automated has a pedestrian door, the system must include a control device inhibiting the operation of the motor when the pedestrian door is open
- Make sure that the controls are kept at a safe distance from moving parts, while allowing a good view of these. Unless a selector is used, the controls should be installed at least 1.5 m from the ground and must not be accessible
- If the opening movement is controlled by a fire-prevention system, make sure that any windows larger than 200 mm are closed by the control elements
- Prevent and avoid any form of trapping between the moving and fixed parts during manoeuvres
- Permanently affix the manual operation label next to the element enabling the manoeuvre itself
- After installing the drive motor, make sure that the mechanism, protective system and all manual manoeuvres operate properly

2 PRODUCT DESCRIPTION AND INTENDED USE

The devices of this kit and other optional accessories belong to the Nice Home automation system and are designed to automate a sliding gate for residential use.

⚠ CAUTION! – Any use other than that specified herein or in environmental conditions other than those stated in this manual is to be considered improper and is forbidden

The kit comprises an electromechanical gearmotor with 24 V direct current; it is equipped with a mechanical release mechanism with key that allows for manually moving the gate in case of a power outage. The gearmotor is equipped with a command control unit that manages the operation of all of the automation.

Connection of the control unit to the various devices occurs through the ECSBus system (a single cable with 2 wires).

The control unit can be powered by fixed mains power (230 V) or, alternatively, through the SOLEKIT photovoltaic system of the Nice Home range. If powered from the mains, it can be fitted with a back-up battery (mod. PR100, optional accessory) which ensures that the automation can execute a certain number of manoeuvres during the hours following a power outage.

3 INSTALLATION

Step A

Step B

⚠ Certain devices and accessories mentioned in this manual are optional and not included in the kit.

⚠ The end stops are not included in the kit and do not belong to the Nice Home range of products.

Consult the Nice Home product catalogue or visit the website www.niceforyou.com

3.1 - VERIFYING THE SUITABILITY OF THE GATE AND ENVIRONMENT

- Ensure that the mechanical structure of the gate is suitable for automation and complies with local standards; consult the technical data appearing on the gate's label. This product cannot automate a gate that is not already secure and efficient; moreover, it cannot resolve defects caused by improper installation of the gate or poor maintenance of the latter.
- Manually move the gate leaf in both directions (open/closed) and make sure that the movement takes place with constant friction at every point along its course (there should be no points requiring more or less effort).
- If the door includes an access door, make sure that it does not obstruct normal movement; mount a suitable interlock system if necessary.
- Manually bring the door of the gate into any position then leave it closed and make sure that it does not move.
- Check that there is no risk of derailment or that the gates may come off their guides.
- Check that there is sufficient space where the gearmotor is installed to allow for effecting a manual release manoeuvre.
- Make sure that the area where the gearmotor is secured is not subject to flooding; if necessary, mount the gearmotor adequately raised from the ground.
- Check that the installation surfaces of the various devices are solid for guaranteeing a stable anchorage and that they are protected and guarded against accidental knocks. For the photocells, choose a flat surface capable of guaranteeing proper alignment of the pair (Tx and Rx).

3.2 - VERIFYING THE PRODUCT'S APPLICATION LIMITS

Before proceeding with the installation, carry out the following checks and verify the "Product technical characteristics" (Paragraph 3.3):

01. Check that the dimensions and weight of the gate leaf fall within the following limits:

FILO400C: maximum length 5,5 m; maximum weight 400 kg

FILO600C: maximum length 7 m; maximum weight 600 kg

02. Check the overall dimensions of the gearmotor (Fig. 2). Note – These measurements also serve as reference to calculate the space required for the foundation excavation for the passage of the cable trays.

03. Check that the estimated durability is compatible with the intended use (Paragraph 2.5).

04. Ensure that all limitations, conditions and warnings appearing in this manual can be fully observed.

3.3 - PRODUCT TECHNICAL SPECIFICATIONS

Model type	FILO400C	FILO600C
Product type	Electromechanical gearmotor for automatic gate and door automations with incorporated control unit, inclusive of radio receiver for ECCO5 transmitters (various models)	
Technology adopted	A 24 V motor --- , reducer with helical gears; mechanical release mechanism. A transformer inside the motor, but separate from the control unit, reduces the mains voltage to the nominal 24 V --- voltage used throughout the automation system.	
Peak thrust	10 Nm	13 Nm
Nominal torque	3.5 Nm	5.2 Nm
Speed (no load)	0.30 m/s	0.20 m/s
Nominal torque speed	0.20 m/s	0.15 m/s
Maximum frequency of cycles	24 cycles/hour at 55°C (40 at 25°C)	11 cycles/hour at 55°C (20 at 25°C)
Maximum continuous cycle time	30 minutes	15 minutes
Application limits	Its structural characteristics make it suitable for use on gates weighing up to 400 kg and up to 5.5 m long.	Its structural characteristics make it suitable for use on gates weighing up to 600 kg and up to 7 m long.
FILO400C/FILO600C mains power supply	230 V \sim (+10% -15%) 50/60Hz	
Maximum power input	370 W	420 W
Emergency power supply	Configured for model PR100 back-up batteries	
Flashing light output	For flashing lights with 12 V (maximum 21 W) bulb	
ECSBus output	One output with maximum load of 10 ECSBus units (1 ECSBus corresponds to the consumption of a pair of photocells)	

SbS input	For normally open contacts (closing of the contact triggers the Step-by-Step (SbS) command)	
Stop input	For normally open contacts and/or for 8.2 kΩ constant resistance, or normally closed contacts with self-recognition of the “normal” status (any variation from the memorised status triggers the Stop command)	
Radio aerial input	50Ω for RG58 or similar type of cable	
Max. cable length	Mains power supply: 30 m; inputs/outputs: 20 m with antenna cable preferably shorter than 5 m (observe the warnings regarding minimum gauge and type of cables)	
Ambient operating temperature	-20°C ... +55°C	
Assembly	-	
Protection rating	IP44	
Dimensions / weight	248 x 216 h 305 mm / 7.5 kg	248 x 216 h 305 mm / 7.5 kg
Possibility of remote control	Using ECCO5... transmitters, the control unit is able to receive one or more of the following commands: Step-by-Step (SbS) - Partial Open - Open Only - Close Only	
Memory capacity	Up to 250 transmitters, if memorised in Mode 1 – 250 keys, if memorised in Mode 2	
ECCO5... transmitter range	From 50 to 100 m. This range can vary if there are obstacles or electromagnetic disturbances and is also affected by the position of the receiving aerial incorporated in the flashing light	
Programmable functions	Operation with “semi-automatic” or “automatic” cycle “Slow” or “fast” motor speeds Pause time during “complete cycle”, selectable from 10, 20, 40, 60 seconds Pedestrian opening type selectable in 4 modes Obstacle detection system motor force, 4 selectable levels Step-by-Step (SbS) command operation selectable in 4 modes	
Self-programmed functions	Self-detection of devices connected to the ECSBus output Self-detection of the type of Stop device (NO or NC contact or 8.2 kΩ resistor) Self-detection of the gate length and calculation of the deceleration points	

ote: in order to improve its products, NICE S.p.A. reserves the right to modify their technical specifications at any time without prior notice. In any case, the manufacturer guarantees their functionality and suitability for their intended use. Note: all technical specifications refer to a temperature of 20°C.

3.4 - PRE-INSTALLATION WORKS

Consult **Fig. 3** to define the approximate installation position of each device mounted on the system; the various elements are positioned according to a standard and customary layout.

Get all the tools and equipment required to complete the job; check that they are in good condition and that they conform to the local safety provisions.

Laying of electrical cables:

01. Observe **Fig. 3** to understand how the various devices should be connected to the control unit and which terminals should be used for each connection. **▲ Only devices adopting the same technology can be connected to the ECSBus.**

The ECSBus system allows for connecting multiple devices together using, between one device and the next, a single “bus” cable, with 2 internal electrical conductors.

The connection between the devices can have a “**cascade**”, a “**star**” or a “**mixed**” configuration, between the first two.

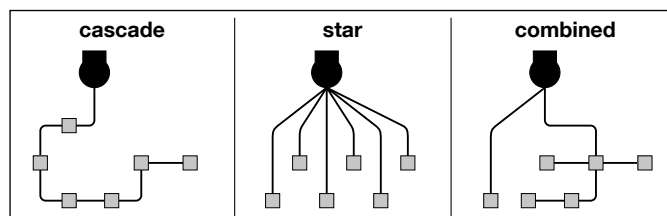

02. Observe **Fig. 3** to understand how to position the electrical cables in the environment (it is advisable to draw on paper a similar layout, adapting it to the relevant requirements).

03. Read **Table 1** to determine the type of cables to be used: **▲ each cable must not exceed the stated maximum length.**

TABLE 1 - Types of electrical cables (see Fig. 3)

Connection	Type of cable	Maximum admissible length
A 230 VAC 50/60 Hz power supply	3 x 1.5 mm ² (not supplied)	30 m *
B Flash flashing light output	2 x 0.5 mm ²	20 m
C Radio aerial	RG58-type shielded cable	20 m (recommended < 5 m)
D ECSBus Input / Output	2 x 0.5 mm ²	20 m **
E Stop input	2 x 0.5 mm ²	20 m **
F SbS (Step-by-Step) input	2 x 0.5 mm ²	20 m **

* it is possible to use a power cable longer than 30 m, provided that it has a larger gauge (for example, 3 x 2.5 mm²) and is equipped with an earthing device, near the automation.

** For the ECSBus cables and the Stop and SbS inputs, it is also possible to use a single cable with multiple internal conductors, to group multiple connections: for example, the Stop and SbS inputs can be connected to the KS100 selector with a cable measuring 4 x 0.5 mm².

CAUTION! – The cables used must be suited to the installation environment; for example a cable of type H03VV-F for indoor environments, or type H07RN-F for outdoor environments.

3.5 - INSTALLING THE FILO GEARMOTOR model 400C/600C

- ▲ **All installation operations must be made with the system disconnected from the power supply. If the back-up battery is present, it must be disconnected**
- **Incorrect installation may cause serious physical injury to those working on or using the system.**
- **Prior to starting, carry out the pre-installation checks stated under Paragraph 3.1.**
- **For the system's correct operation, it is necessary to include mechanical stops (not provided with the kit) on the ground or wall, positioned at the maximum opening and closing points of the gate leaf.**

If the rack must be installed: see Par. 3.5.1

If the rack is already present: see Par. 3.5.2

3.5.1 - INSTALLATION WITH RACK TO BE INSTALLED (Fig. 4)

01. Observe the measurements to be used for positioning the foundation plate, depending on the position chosen for the motor's installation (Phase 01 - Fig. 4)
02. Excavate a suitably sized foundation hole and arrange one or more tubes for feeding the electrical cables (Phase 02 - Fig. 4): leave the tubes longer than 40 cm.
03. Pour the concrete, while keeping away the tubes for the cables (Phase 03 - Fig. 4)
04. - Mount the two anchor bolts on the foundation plate using two nuts for every anchor bolt: a normal nut fastened beneath the plate and a self-locking nut fastened above it (on the side containing the image of the pinion): **Phase 04 - Fig. 4**
 - Place the foundation plate above the concrete, by putting the side with the image of the pinion towards the gate and making sure that the plate lies parallel to the gate leaf and perfectly level (Phase 04 - Fig. 4)
 - Ensure that the tubes for passing the electrical cables come out of the hole on the plate (Phase 04 - Fig. 4)
05. Wait for the concrete to harden (Phase 05 - Fig. 4)
06. When the concrete is sufficiently dry (after a few days), remove the 2 upper nuts and keep them to fasten the gearmotor (Phase 06 - Fig. 4)
07. Fasten the two mechanical stops (not supplied) as shown in Phase 07 - Fig. 4
08. Open the gearmotor's cover **Phase 08 - Fig. 4**
09. Shorten the tubes for protecting the cable by 20/30 mm and place the gearmotor on the plate (Phase 09 - Fig. 4)
10. Manually release the gearmotor (Phase 10 - Fig. 4)
11. Insert the washers on the pins and screw on the self-locking nuts (provided), without tightening them strongly (Phase 11 - Fig. 4). ▲ Check that the motor and the gate leaf lie perfectly parallel to one another then tighten the nuts strongly
12. Take a 2–3 cm spacer and place it in front of the mechanical stop (Phase 12 - Fig. 4), then manually move the gate towards the mechanical stop while making it lie on the spacer
13. Place the first section of the rack above the pinion of the gearmotor (Phase 13 - Fig. 4). ▲ **CAUTION!** - Leave a 1–2 mm gap between the rack and pinion (this applies to all parts!), so that the weight of the gate does not bear on the motor. The rack must protrude by a few centimetres with respect to the pinion's vertical axis
14. Proceed by securing the other parts of the rack in succession: to keep the rack horizontal, mark its fixing hole when the slot lies on the vertical axis of the pinion. Repeat this operation for all fastening positions (Phase 14 - Fig. 4)
15. After having fastened the last part of the rack, if it protrudes from the gate, cut the part in excess (Phase 15 - Fig. 4). ▲ The rack must not protrude from the gate
16. Take a 2–3 cm spacer and place it in front of the mechanical stop (Phase 16 - Fig. 4), then manually move the gate towards the mechanical stop while making it lie on the spacer. When moving the gate, make sure that the rack slides regularly over the pinion
17. Manually lock the gearmotor (Phase 17 - Fig. 4).

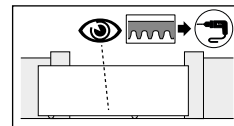

At this point it is possible to install the accessories that belong to the system: for photocells PH200 > Par. 3.6 (Fig. 6) - for flashing light FL200 > Par. 3.7 (Fig. 7). For other optional accessories, consult the respective instruction manuals.

3.5.2 - INSTALLATION WITH RACK ALREADY MOUNTED (Fig. 5)

- ▲ **Warning:** - Before securing the gearmotor, check that the existing rack is compatible with the pinion's overall dimensions. - Make sure that the distance between successive teeth on the rack is 12 mm.
01. Observe the measurements to be used for positioning the foundation plate, depending on the position chosen for the motor's installation (Phase 01 - Fig. 5)
 02. Excavate a suitably sized foundation hole and arrange one or more tubes for feeding the electrical cables (Phase 02 - Fig. 5): leave the tubes longer than 40 cm.
 03. Pour the concrete, while keeping away the tubes for the cables (Phase 03 - Fig. 5)
 04. - Mount the two anchor bolts on the foundation plate using two nuts for every anchor bolt: a normal nut fastened beneath the plate and a self-locking nut fastened above it (on the side containing the image of the pinion): **Phase 04 - Fig. 5**
 - Place the foundation plate above the concrete, by putting the side with the image of the pinion towards the gate and making sure that the plate lies parallel to the gate leaf and perfectly level (Phase 04 - Fig. 5)
 - Ensure that the tubes for passing the electrical cables come out of the hole on the plate (Phase 04 - Fig. 4)
 05. Wait for the concrete to harden (Phase 05 - Fig. 5)
 06. When the concrete is sufficiently dry (after a few days), remove the 2 upper nuts and keep them to fasten the gearmotor (Phase 06 - Fig. 5)
 07. Fasten the two mechanical stops (not supplied) as shown in Phase 07 - Fig. 5
 08. Open the gearmotor's cover **Phase 08 - Fig. 5**
 09. Shorten the tubes for protecting the cable by 20/30 mm and place the gearmotor on the plate (Phase 09 - Fig. 5)
 10. Manually release the gearmotor (Phase 10 - Fig. 5)
 11. Insert the washers on the pins and screw on the self-locking nuts (provided), without tightening them strongly (Phase 11 - Fig. 4). ▲ Check that the motor and the gate leaf lie perfectly parallel to one another then tighten the nuts strongly
 12. Take a 2–3 cm spacer and place it in front of the mechanical stop (Phase 12 - Fig. 5), then manually move the gate towards the mechanical stop while making it lie on the spacer
 13. If necessary, adjust the height of the rack above the pinion of the gearmotor (Phase 13 - Fig. 5). **CAUTION!** - Leave a 1–2 mm gap between the rack and pinion (this applies to all parts!), so that the weight of the gate does not bear on the motor
 14. Take a 2–3 cm spacer and lace it in front of the mechanical stop (Phase 14 - Fig. 5). Next, manually move the gate towards the mechanical stop while making it lie on the spacer. When moving the gate, make sure that the rack slides regularly over the pinion
 15. Lastly, bring the gate to half its path (with respect to the two limit switches) and manually lock the gearmotor (Phase 15 - Fig. 5).

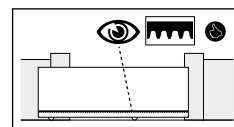

At this point it is possible to install the accessories that belong to the system: for photocells PH200 > Par. 3.6 (Fig. 6) - for flashing light FL200 > Par. 3.7 (Fig. 7). For other optional accessories, consult the respective instruction manuals.

3.6 - INSTALLING THE PHOTOCELLS model PH200 (Fig. 6a - 6b)



The photocells can be mounted on the wall as described below (fig. 6a), or inside the gearmotor (fig. 6b); for this type of installation, consult the instruction manual of the photocells.

- ▲ position each photocell 40/60 cm above the ground
- position them on the opposite sides of the zone to be protected
- position them as close as possible to the gate (maximum distance = 15 cm)
- a tube for passing the cables must be present in the fastening point
- orient the TX transmitter towards the central zone of the RX receiver (allowed misalignment: maximum 5°)

For the installation procedure see Fig. 6a - 6b.

3.7 - INSTALLING THE FLASHING LIGHT model FL200 (Fig. 7)



- ▲ The flashing light must be positioned near the gate in a clearly visible position. It can be fasted to a horizontal or vertical surface.
- For connection to the Flash terminal, no polarity needs to be observed; instead for connection of the shielded aerial cable, it is necessary to connect the cable and sheath as shown in Fig. 8.

Choose the most suitable position in which to install the flashing light: it must be positioned near the gate in a clearly visible position. It can be fasted to a horizontal or vertical surface.

For the installation procedure see Fig. 7.

4 ELECTRICAL CONNECTIONS

Step C



4.1 - ELECTRICAL CONNECTION TO THE CONTROL UNIT (Fig. 8)

01. Perforate the rubber membrane and insert the cables necessary to connect the various devices (Phase 01 - Fig. 8): leave the cables at least 40-50 cm long and secure them with cable ties (Phase 02 - Fig. 8).
02. Connect the various devices of the kit and any other components designed for being used on the system (optional and not included in the package) (Phase 03 - Fig. 8): It is not necessary to observe any polarity, with the exception of the shielded aerial cable which must be connected with the cable and sheath as shown in Phase 03 - Fig. 8

4.2 - POWER SUPPLY CONNECTION

▲ CAUTION! - The final connection of the system to the mains power or replacement of the cable supplied MUST be performed exclusively by a qualified and electrician, in compliance with local safety standards and the following instructions.

- For operational and programming tests of the automation, use the cable supplied, inserting the plug into an electrical socket. If the socket is a long way from the automation, an extension may be used in this phase.
- For the testing and commissioning phase of the automation, it is necessary to connect the control unit permanently to the mains power supply, by replacing the supplied cable. To connect the cable to the gearmotor's control unit, proceed as described below:

01. Make sure that the gearmotor plug is not plugged into the wall socket.
02. Disconnect the power cable from the gearmotor's power supply terminal (Fig.10).
03. Loosen the collar and remove the power cable: replace it with the permanent power cable.
04. Connect the power cable to the gearmotor's power supply terminal (Fig. 11).
05. Tighten the collar to secure the electric cable.
06. Before closing the gearmotor's cover (Fig. 9) it is possible to programme the control unit (see Chapter 5).

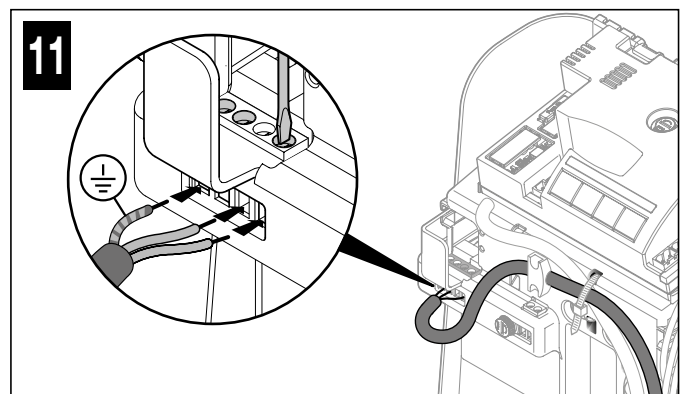
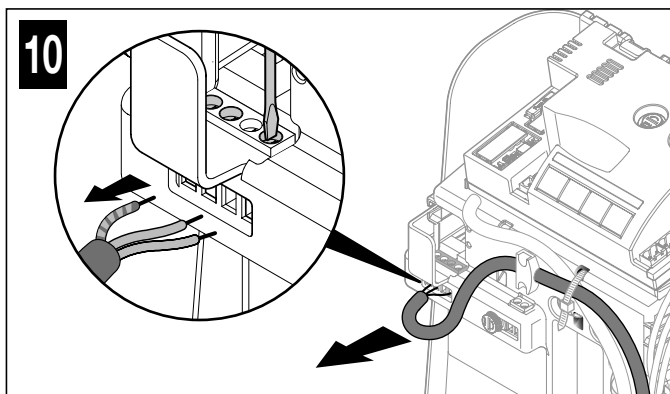

5.1 - CONTROL UNIT KEYS

The control unit has four programming keys with their respective LEDs: **keys P1, P2, P3, P4** and **LEDs L1, L2, L3, L4** (Fig. 12)

P1 = **Step-by-Step** command

P2 = **slow/fast movement speed** selection (Par. 5.6.1)

P3 = **semi-automatic/automatic operating cycle** selection (Par. 5.6.2)

P4 = **radio transmitter** memorisation

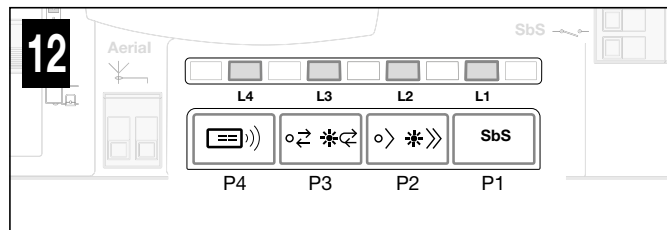

5.2 - PRELIMINARY CHECKS

After powering up the control unit, a few straightforward checks should be carried out:

01. Depending on the gearmotor's installation position (to the right or left of the gate), shift the selector as shown in **Fig. 13** to determine the gate's opening direction.
02. **Check on the control unit (Fig. 14)** that the **ECSBus led** flashes normally (roughly one flash each second).
02. **On the Tx and Rx photocells (Fig. 15)** check that the **SAFE led** flashes: the type of flash is unimportant as it depends on other factors; however, it is important that the led is not always off or always lit.
03. If all these checks are non-conforming, disconnect the power supply to the control unit and check the relevant connections of the cables. Other useful information is contained in Chapters 9.9 and 10.

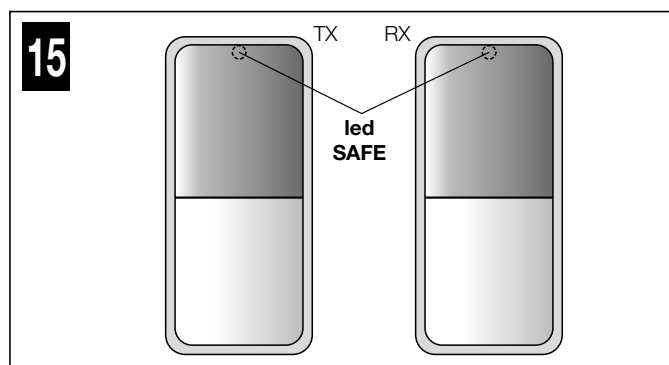
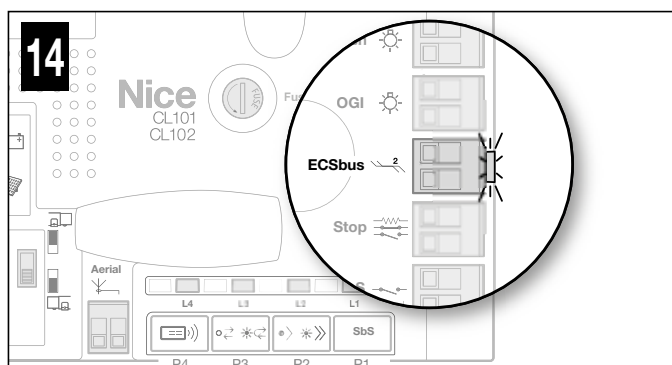
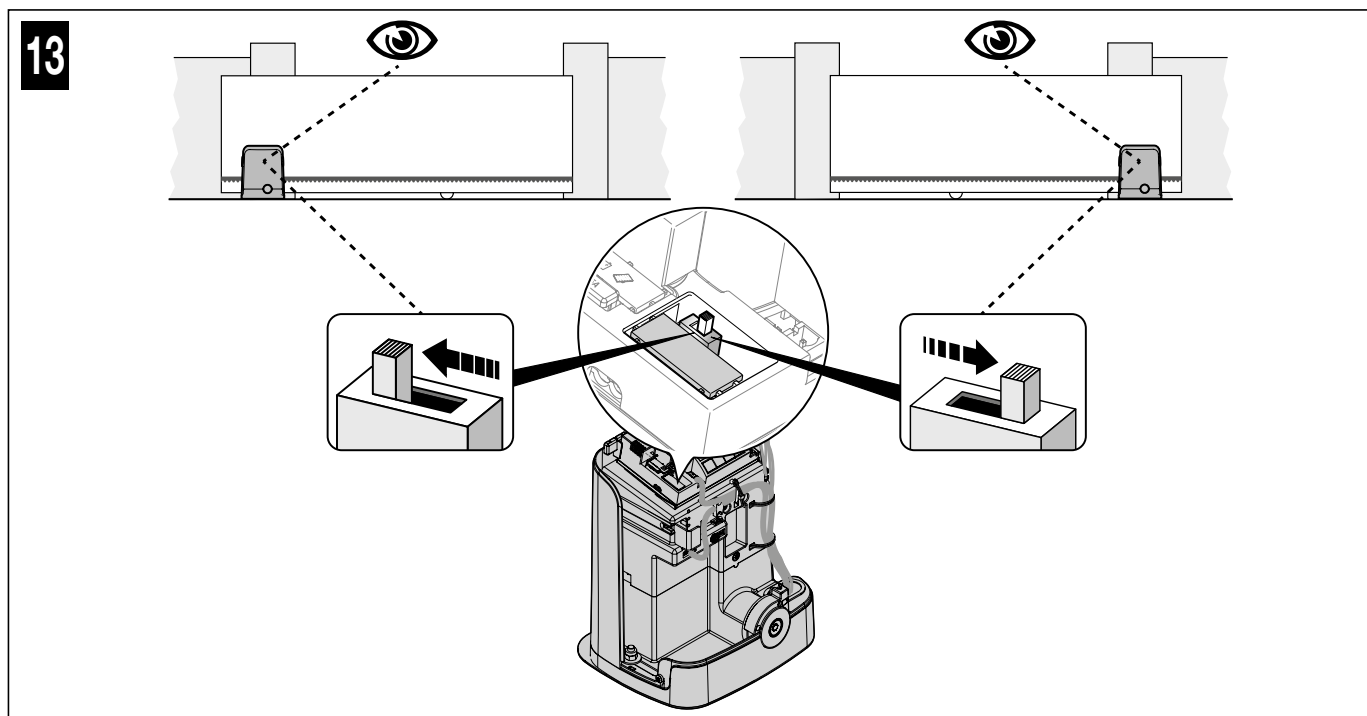

5.3 - MEMORISATION OF CONNECTED DEVICES

On completion of the preliminary checks (Par. 5.2), the control unit must be made to recognise the devices connected on the **ECSBus** and **Stop** terminals.

01. **On the control unit (Fig. 16)** press and hold **button P2** for at least 3 seconds then release it.
02. Wait a few seconds for the control unit to complete the device learning phase.
03. **On the control unit (Fig. 17)**, at the end of the recognition procedure, the **Stop led** must remain lit and **led L2** must turn off. The **ECSBus led** must flash once each second. If **led L2** flashes = error (see Chapter 10).

⚠ Whenever a photocell is added to or removed from the system, the recognition procedure for the connected devices must be repeated.

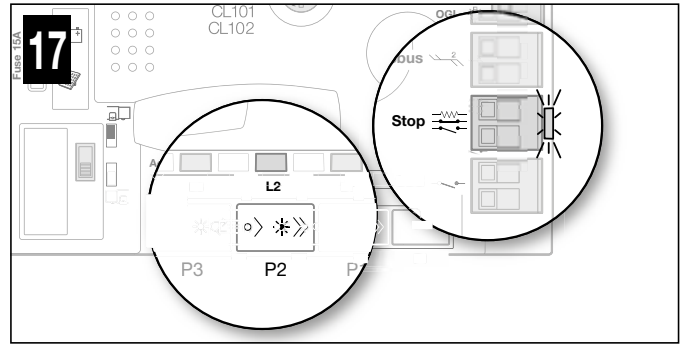
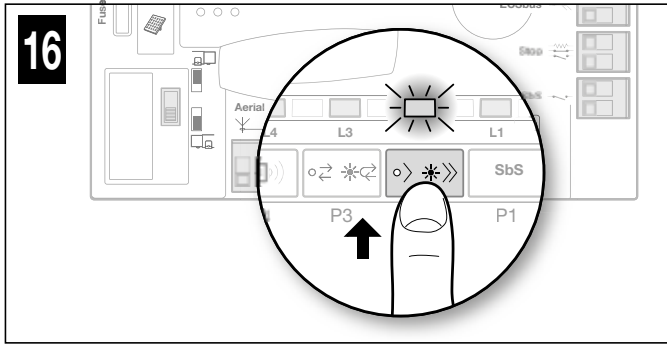

5.4 - MEMORISATION OF THE GATE LEAF LENGTH (opening and closing)

After recognition of the devices (Par. 5.3) it is necessary to make the control unit memorise the length of the gate leaf, which is measured from the closing limit switch to the opening limit switch. This operation is also required to calculate the deceleration points and the partial open point.

01. On the control unit (Fig. 18) press and release **button P1**: wait for the control unit to execute the gate opening manoeuvre up to the opening limit switch. **Only if the manoeuvre is NOT an opening movement**, proceed as follows: a) press and release button P1 to lock the manoeuvre – b) shut off power to the control unit – c) invert the position of the selector on the control unit (Fig. 19) – d) restore power to the control unit – e) press and release button P1.

02. On the control unit (Fig. 19) press and release **button P1**: wait for the control unit to execute the gate closing manoeuvre up to the closing limit switch.

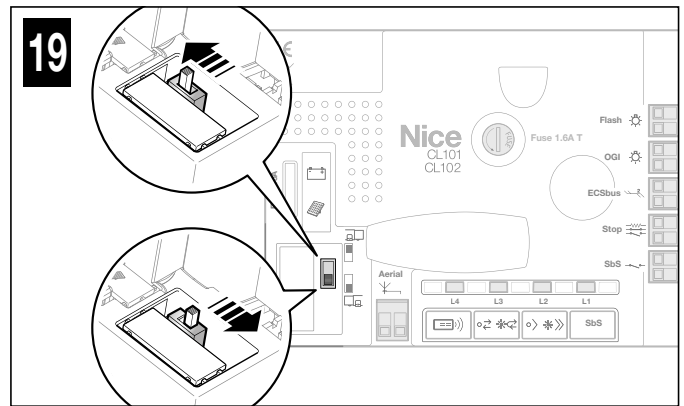
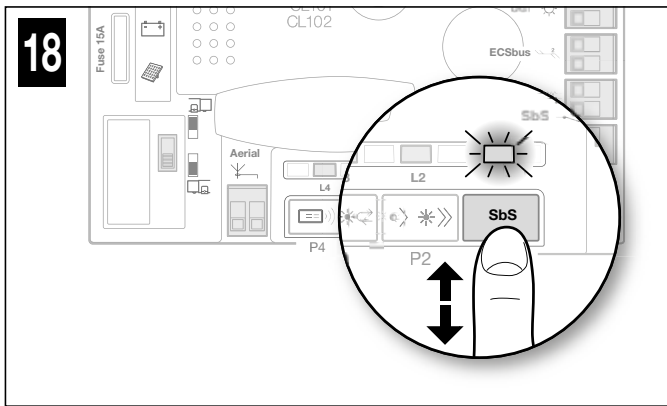

03. Lastly, perform various opening and closing manoeuvres while checking that the gate leaf stops at least 2/3 cm from the mechanical stops during both the opening and closing phases (Fig. 20). If this distance does not match the proper distance, it can be modified accurately (for both limit switches or only one), as shown in Fig. 21:

1) send a command to bring the gate leaf to the limit switch to be adjusted (opening or closing) - **2)** inside the gearmotor and using the Allen key provided, **calibrate (+ ... -) the screw for adjusting the knob located in the highest position** until the gate reaches a distance of 2-3 cm from the mechanical stop. Repeat the same operation for the other limit switch, if necessary.

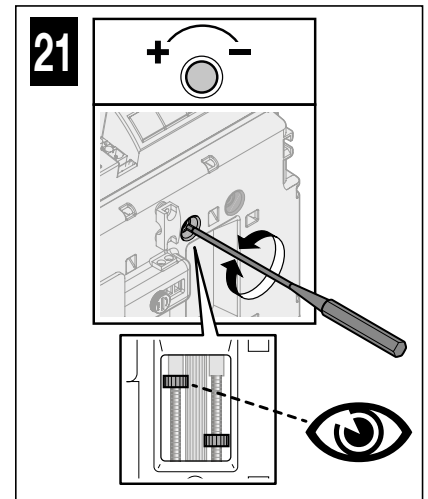
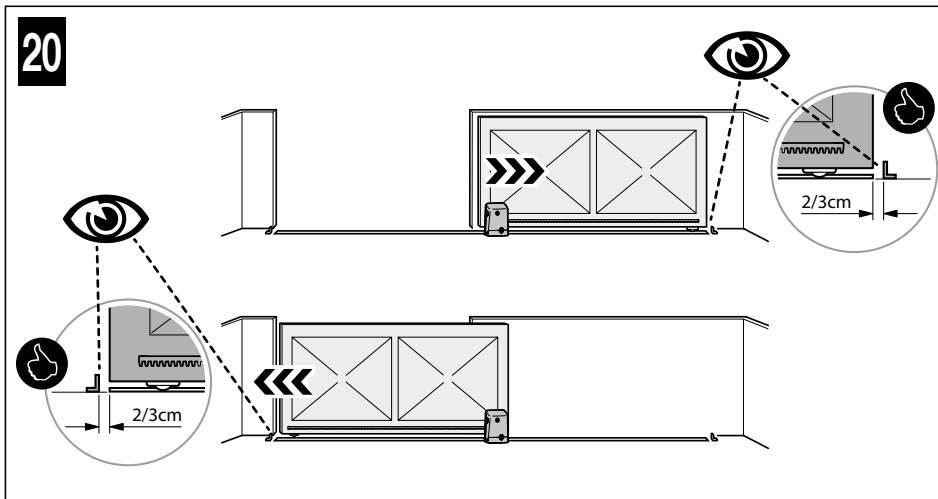

5.5 - MEMORISATION OF THE 1st TRANSMITTER

The control unit incorporates a radio receiver for ECCO5 transmitters (various models): before proceeding with the remaining steps, it is necessary to memorise the 1st transmitter in Mode 1 – see procedure below.

To memorise additional transmitters, see Par. 9.3.

⚠ Before running the memorisation procedure, it is advisable to read it and observe the indicated times.

This procedure allows for **simultaneously memorising all the transmitter keys**, by automatically pairing them to the commands shown in **Table 1** below.

A transmitter memorised in Mode 1 can control only a single automation.

TABLE 1

Keys	Paired command
T1	Step-by-Step (SbS)
T2	Partial open
T3	Open only
T4	Close only
T5	230 V light output: On - Off

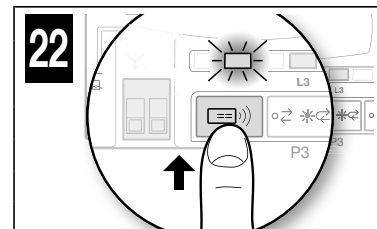
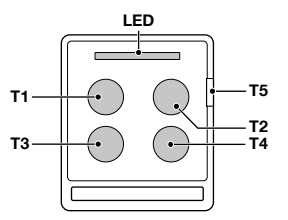

Memorisation procedure

01. On the control unit (Fig. 22) press and hold **button P4** for 3 seconds; when **led L4** switches on, release the button.
02. Within 10 seconds from releasing it, press and hold for 3 seconds any button of the transmitter to be memorised.
If the memorisation procedure is successful, led L4 (on the control unit) will flash 3 times.
03. To memorise other transmitters, repeat step 02 within the next 10 seconds otherwise the memorisation phase will terminate automatically.

5.6 - BASIC ADJUSTMENTS

5.6.1 - Choosing the gate manoeuvre speed

The opening and closing manoeuvre speed of the gate can be either **“slow”** or **“fast”** (the type of selection chosen is visualised by the switching on or off of led L2 on the control unit – Fig. 23):

Led **L2 off** = the **“slow”** manoeuvre speed was selected.

Led **L2 on** = the **“fast”** manoeuvre speed was selected.

Procedure for selecting the desired speed

01. Press and release **button P2** to invert the operating mode from slow to fast and vice-versa (Fig. 23).

5.6.2 - Choosing the gate manoeuvre operating cycle

The “opening and closing” manoeuvre cycle of the gate can be either **“semi-automatic”** or **“automatic”** (the type of selection chosen is visualised by the switching on or off of led L3 on the control unit – Fig. 24):

Led **L3 off** = the **“semi-automatic”** manoeuvre cycle was selected (with the first command the gate opens and stays open until the next command that causes it to close).

Led **L3 lit** = the **“automatic”** manoeuvre cycle was selected (with a single command the gate opens and re-closes automatically after a set time – to adjust the pause time see Par. 9.1.1).

Procedure for selecting the desired cycle

01. Press and release **button P3** to invert the operating mode from semi-automatic to automatic and vice-versa (Fig. 24).

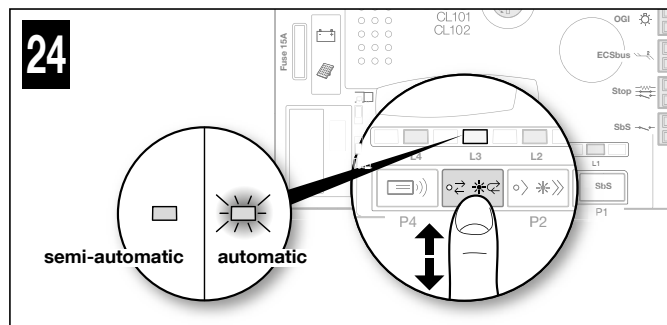
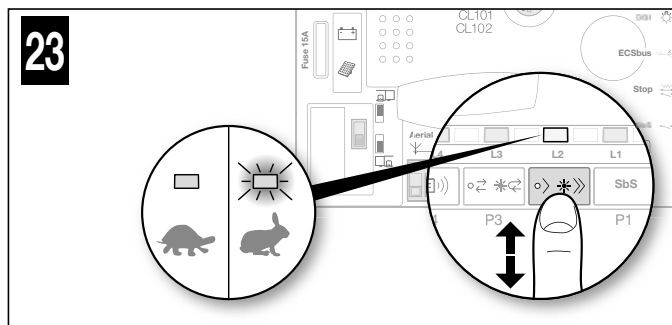

6 TESTING AND COMMISSIONING



CAUTION! – The system must be tested by skilled and qualified personnel, who is responsible for defining the tests adopted in relation to the risks present, and for ensuring observance of all legal provisions, standards and regulations, with particular reference to all requirements of the EN 13241-1, EN 12445 and EN 12453 standards which defines the test methods for testing gate automations.

6.1 - TESTING

01. Ensure that all the instructions and warnings indicated in Chapter 1 have been strictly observed.
02. Using the transmitter, test the gate's opening and closing movements and ensure that the leaf movement corresponds to specifications. A number of tests should be performed to ensure that the gate moves smoothly and that there are no assembly defects, incorrect settings, or any points of friction.
03. Check the operation of all the system's safety devices one-by-one (photocells, sensitive edges, etc.) In particular, whenever a device is activated the ECsBus led (on the control unit) must emit a longer flash to confirm that the control unit has recognised the event.
04. To check the photocells and make sure that there is no interference with other devices, pass a cylinder with 5 cm diameter and 30 cm length on the optical axis, first near the TX then near the RX and, lastly, at the mid-point between the two, and verify that in all these cases the device is triggered, switching from the active status to the alarm status and vice-versa; lastly, make sure that it causes the intended action in the control unit; for example: reversal of the movement during the closing manoeuvre.
05. Measure the impact force as specified in the EN 12445 and EN 12453 standards. If the “motor force” control is used as an auxiliary function to reduce the impact force, test and identify the setting that obtains the best results.

6.2 - COMMISSIONING

Commissioning can only be performed after all test phases have been successfully completed. Partial or “makeshift” commissioning is strictly prohibited.

01. Draw up the technical file of the automation which should at least include: assembly drawing (for example as in Fig. 3), wiring diagram (for example Fig. 8), risk analysis and relative solutions adopted, the manufacturer's declaration of conformity for all the devices used.
02. Affix a dataplate on the door, specifying at least the following data: type of automation, name and address of manufacturer (responsible for "commissioning"), serial number, year of construction and "CE" marking.
03. Permanently attach to the gate the label supplied in the pack, regarding the procedure for manual locking/release of the gearmotor.
04. Fill in the declaration of conformity and hand it to the owner of the automation (Annex 1).
05. Draw up and hand to the owner of the automation the user guide (Chapter 11 – detachable insert).
06. Prepare and provide the owner with the "Maintenance schedule" form, containing all maintenance instructions for all devices in the automation.
07. Before commissioning the automation, ensure that the owner is properly informed of all risks and hazards still present.

7 MAINTENANCE

Maintenance must be performed in strict observance of the safety provisions in this manual and according to current legislation and standards.

The automation's devices do not require special maintenance; however they should be checked periodically (at least every six months) to ensure complete their full efficiency.

To this aim, run all the tests and checks specified under Paragraph 6.1 and consult the maintenance plan of the respective instruction manuals.

8 PRODUCT DISPOSAL

This product is an integral part of the automation and therefore must be disposed together with the latter.

As in installation, also at the end of product lifetime, the disassembly and scrapping operations must be performed by qualified personnel.

This product is made of various types of materials, some of which can be recycled while others must be scrapped. Seek information on the recycling and disposal systems required by local regulations in your area for this product category.

Caution! – certain parts of the product may contain polluting or hazardous substances that, if released into the environment, may seriously damage the environment and human health.

As indicated by the adjacent symbol, the product may not be disposed of together with domestic waste. Separate the waste into categories for disposal, according to the methods set out by legislation in force in your area, or return the product to the retailer when purchasing a new version.



Caution! – local regulations may include the application of heavy fines in the event of improper disposal of this product.

9 FURTHER INFORMATION

9.1 - ADVANCED SETTINGS

9.1.1 - Adjusting the parameters (using the transmitter memorised in mode 1)

The transmitter can be used to set a number of control unit operating parameters:

- **Pause time:** time during which the gate remains open before re-closing automatically (if the “automatic closing” function is set).
- **Pedestrian opening:** partial opening mode of the gate, to allow pedestrians to pass through.
- **Motor force:** maximum force applied by the motor to move the gate; when this value is exceeded, the control unit interprets the occurrence as an obstacle stopping the gate and, consequently, inverts the direction of movement.
- **SbS Function:** sequence of gate movements associated with the Step-by-Step (SbS) command.
- **OGI (Open Gate Indicator) function:** output to which it is possible to connect a 24 V maximum 4 W warning light.

The adjustment can be effected by means of any transmitter memorised in Mode 1 (as those supplied, see Paragraph 9.3.1). If there is no transmitter memorised in Mode 1, it is possible to memorise one solely for programming purposes then cancelling it (see Paragraph 9.4).

All parameters can be adjusted as desired, with the exception of the “motor force” parameter, which requires special attention:

- Do not use high force values to compensate for abnormal friction points along the gate's path: excessive force may adversely affect the operation of the safety system or damage the gate itself.
- If the “motor force” control is used to assist the impact force reduction system, measure the force again after each adjustment in compliance with the EN 12445 and EN 12453 standards.
- Weather conditions may affect the movement of the gate, so the latter should be readjusted periodically.

Adjustment procedure (before proceeding check the parameter to be modified in Table 2 and the action to be performed):

01. **On the transmitter (Fig. 26)** simultaneously press and hold **keys T1 and T2** for 5 seconds then release them.
02. Within 3 seconds from releasing them, perform the action specified in **Table 2** to modify the desired parameter.

TABLE 2

Parameters	Value	No. of flashes emitted by the flashing light	Transmitter key to be used	Actions to be performed
Pause time	10 sec	1	T1	Press T1 once
	20 sec *	2	T1	Press T1 twice
	40 sec	3	T1	Press T1 three times
	60 sec	4	T1	Press T1 four times
Pedestrian opening	Gate open to 0.7 m	1	T2	Press T2 once
	Gate open to 1 m *	2	T2	Press T2 twice
	Gate halfway open	3	T2	Press T2 three times
	Gate 3/4 open	4	T2	Press T2 four times
Motor force	Low	1	T3	Press T3 once
	Medium-low *	2	T3	Press T3 twice
	Medium-high	3	T3	Press T3 three times
	High	4	T3	Press T3 four times
Step-by-Step (SbS) function	Open - Stop - Close - Stop	1	T4	Press T4 once
	Open - Stop - Close - Open *	2	T4	Press T4 twice
	Open - Close - Open - Close	3	T4	Press T4 three times
	Opening only	4	T4	Press T4 four times
OGI (Open Gate Indicator) function	OGI	1	T5	Press T5 once
	30 sec courtesy light	2	T5	Press T5 twice
	60 sec courtesy light	3	T5	Press T5 three times
	Presence function* (see Par. 9.1.2)	4	T5	Press T5 four times

* Factory value

9.1.2 - Presence function

This function is regulated by **key T5** of the ECCO5... transmitter (Fig. in Table 4) and determines the operating mode of the OGI output. If LM100 lighting modules (not supplied) are connected to this output, this function operates as follows:

- **with the gate closed:** when an opaque object interrupts transmission (infrared) of the photocells, the courtesy light switches on for 5 seconds. After 5 seconds, if the transmission is still interrupted, the courtesy light switches on for another 5 seconds; if instead the photocell does not detect any object, the courtesy light switches off.
- **with the gate moving (opening and closing manoeuvre):** the courtesy light is always lit. At the end of the manoeuvre (opening or closing) it remains lit for a further 5 seconds.
- **with the gate open and automatic closing not active:** at the end of the manoeuvre the courtesy light remains lit for 5 seconds then switches off and follows the gate's behaviour when closed.
- **with the gate open and automatic closing active:** at the end of the manoeuvre the courtesy light remains lit for 5 seconds then switches off and follows the gate's behaviour when closed.

If the OGI function is active, the lamp connected to it behaves in the following way:

- **off:** automation in fully closed position.
- **slow flashing:** execution of the opening manoeuvre.
- **fast flashing:** execution of the closing manoeuvre.
- **steady lit:** automation in fully open position.

9.1.3 - Verifying the values set for each parameter (using the transmitter memorised in mode 1)

The check can be effected by means of any transmitter memorised in Mode 1 (as those supplied, see Paragraph 9.3.1). If there is no transmitter memorised in Mode 1, it is possible to memorise one solely for programming purposes then cancelling it (see Paragraph 9.4).

Adjustment procedure (before proceeding check the parameter to be verified in Table 3 and the action to be performed):

- 01. On the transmitter (Fig. 25)** simultaneously press and hold **buttons T1 and T2** for 5 seconds then release them.
- 02. Within 3 seconds** from releasing them, perform the action specified in **Table 3** to verify the desired parameter.
- 03. Release the key** when the flashing light starts flashing: count the flashes. Check in Table 2 the value corresponding to the number of flashes.

TABLE 3

Parameters	Actions to be performed
Pause time	Press and hold key T1
Pedestrian opening	Press and hold key T2
Motor force	Press and hold key T3
SbS function	Press and hold key T4
OGI function	Press and hold key T5

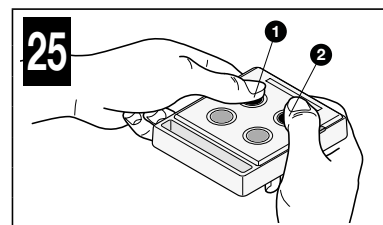

9.2 - ADDING OR REMOVING DEVICES

It is possible to add or remove devices at any time to the system: if devices are added, it is important to verify that these are perfectly compatible with FILO 400C/FILO 600C; for further details contact the Nice technical support service.

9.2.1 - Memorising additional devices

The recognition operation of the devices connected to the ECsBus and to the Stop input is usually carried out during the installation phase; but if devices are added (or removed) subsequently, the following procedure must be carried out:

- 01. On the control unit** press and hold **button P2 (Fig. 26)** for at least 3 seconds then release it.

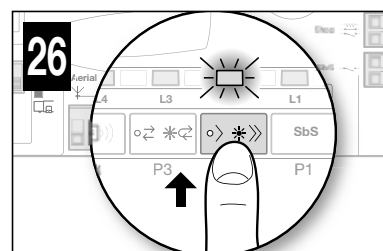

02. Wait a few seconds until the control unit has completed the device recognition procedure: led L2 switches off. If instead it flashes, it means that there is some error – see Chapter 10.
03. After adding or removing devices, the automation must be tested again (Par. 6.1).

9.3 - MEMORISING ADDITIONAL TRANSMITTERS

The control unit incorporates a radio receiver for ECCO5 transmitters (various models). The transmitters supplied are not memorised, therefore it is first necessary to memorise the 1st transmitter (Par. 5.6); to memorise additional transmitters, it is possible to choose one of the procedures (Mode 1 or Mode 2) indicated below. The control unit can memorise a total of 250 units: memorisation in Mode 1 occupies one unit of memory for each transmitter, while the Mode 2 procedure occupies one unit of memory for each transmitter key.

▲ Before running the memorisation procedures, it is advisable to read them and observe the indicated times.

9.3.1 - Mode 1 memorisation procedure (factory memorisation of the supplied transmitters)

This procedure allows for simultaneously memorising all the transmitter keys, by automatically pairing them to the commands shown in **Table 4**. **A transmitter memorised in Mode 1 can control only a single automation.**

Keys	Paired command
T1	Step-by-step
T2	Partial open
T3	Open only
T4	Close only
T5	Courtesy light: Lit - Off

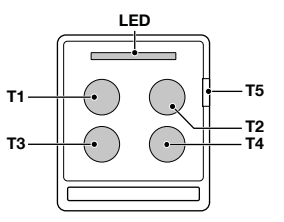
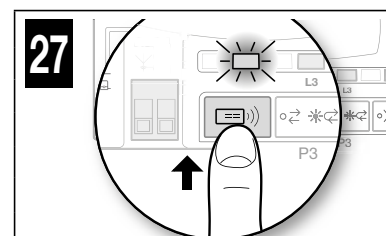
Memorisation procedure

01. **On the control unit (Fig. 27)** press and hold **button P4** for 3 seconds; when **led L4** switches on, release the button.
02. Within 10 seconds from releasing it, press and hold for 3 seconds any button of the transmitter to be memorised. If the memorisation procedure is successful, led L4 (on the control unit) will flash 3 times.
03. To memorise other transmitters, repeat step 02 within the next 10 seconds otherwise the memorisation phase will terminate automatically.

9.3.2 - Mode 2 memorisation procedure

This procedure allows for memorising one key at a time, by pairing one of the desired commands shown in **Table 5**.

A transmitter memorised in Mode 2 can control multiple automations (for example: automation 1 controlled by key 1; automation 2 controlled by key 2; and so forth)

No. of key presses	Paired command	No. of flashes of led L4 on the control unit
once	Step-by-step	1
twice	Pedestrian opening	2
3 times	Open only	3
4 times	Close only	4
5 times	230 V light output: On - Off	14
6 times	Stop	6
7 times	Condominium open	7
8 times	High priority open	8
9 times	Pedestrian opening 2	9
10 times	Pedestrian opening 3	10
11 times	Open + lock automation	11
12 times	Close + lock automation	12
13 times	Lock automation	13
14 times	Release automation	14

Memorisation procedure

01. **Before proceeding, it is necessary to cancel the memory of the transmitter to be memorised – see Par. 9.4.**
02. In **Table 5**, choose the command and the number of press-down actions to be effected on the desired transmitter key.
03. **On the control unit (Fig. 28)** press and release **button P4** for a number of times corresponding to the chosen command (Table 5); **led L4** must emit a number of fast flashes corresponding to the chosen command.
04. Within 10 seconds, press and hold for 2 seconds the key of the transmitter to be memorised: if the memorisation was successful, **led L4** (on the control unit) will flash 3 times.
05. To memorise other transmitters, with the same command, repeat step 03 within 10 seconds, otherwise the memorisation phase will terminate automatically.

9.3.3 - Memorisation procedure near the control unit with two transmitters (without using the control unit keys)

With this procedure a NEW transmitter is memorised using a second transmitter (OLD) already memorised and operating, without using the keys of the control unit but drawing close to the latter.

During the procedure the NEW transmitter is memorised in the same way that the OLD transmitter was memorised (Mode 1 or Mode 2).

• Procedure with OLD transmitter memorised in Mode 1:

01. Draw near the control unit with the two transmitters: **▲ Wait 1 second between one step and the next.**
02. **On the NEW transmitter** press and hold any key for at least **8 seconds** then release it.
03. **On the OLD transmitter** press and hold any key to be copied for at least **2 seconds** then release it.
04. **On the OLD transmitter** press and hold any key to be copied for at least **2 seconds** then release it.
05. **On the OLD transmitter** press and hold any key to be copied for at least **2 seconds** then release it.
06. **On the NEW transmitter** press and hold a key to be memorised for at least **5 seconds** then release it.

Repeat the procedure for each transmitter to be memorised.

• Procedure with OLD transmitter memorised in Mode 2:

01. Draw near the control unit with the two transmitters: **▲ Wait 1 second between one step and the next.**
02. **On the NEW transmitter** press and hold the key to be memorised for at least **8 seconds** then

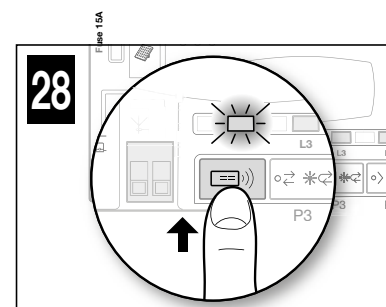

release it.

03. **On the OLD transmitter** press and hold the key to be copied for at least **2 seconds** then release it.
04. **On the OLD transmitter** press and hold the key to be copied for at least **2 seconds** then release it.
05. **On the OLD transmitter** press and hold the key to be copied for at least **2 seconds** then release it.
06. **On the NEW transmitter** press and hold the key to be memorised for at least **5 seconds** then release it.

Repeat the procedure for each transmitter to be memorised.

9.4 - DELETING THE MEMORY OF THE INDIVIDUAL TRANSMITTER FROM THE CONTROL UNIT'S MEMORY

This procedure allows for cancelling a single transmitter (memorised in Mode 1) or only one of its keys (memorised in Mode 2): it is necessary to arrange the transmitter to be cancelled and simultaneously be able to access the control unit (before proceeding, open the gearmotor – Fig. 9).

• Procedure with transmitter memorised in Mode 1:

01. **On the control unit (Fig. 28)** press and hold **button P4 until the end of the procedure.**
02. When **led L4** lights up, while keeping button P4 pressed, press and hold also **any button** of the transmitter to be cancelled, until **led L4** flashes quickly 5 times, then release both buttons.

Repeat the procedure for each transmitter to be cancelled.

• Procedure with transmitter memorised in Mode 2:

01. **On the control unit (Fig. 28)** press and hold **button P4 until the end of the procedure.**
02. When **led L4** lights up, while keeping button P4 pressed, press and hold also **the button** of the transmitter to be cancelled, until **led L4** flashes quickly 5 times, then release both buttons

Repeat the procedure for each transmitter to be cancelled.

9.5 - COMPLETE DELETION OF THE RADIO MEMORY

This procedure allows for cancelling ALL memorised transmitters: the procedure must be carried out on the control unit (before proceeding, open the cover of the gearmotor – Fig. 9).

01. **On the control unit (Fig. 28)** press and hold **button P4.**
02. Check that **led L4** lights up for 4/5 seconds, that it switches off then flashes 3 times.
03. Precisely at the 3rd flash release **button P4.**
04. Check that **led L4** emits very fast flashes.
05. Check that **led L4** emits 5 slow flashes = deletion completed.

9.6 - INSTALLING THE BACK-UP BATTERY (model PR100)

⚠ CAUTION! - The electrical connection of the back-up battery to the control unit **must be made exclusively after completing all the installation and programming stages, as the battery is an emergency power supply.**

To install the back-up battery and connect it to the control unit, see **Fig. 29** and consult the respective instruction manual.

When the automation is powered by the back-up battery, 60 seconds after a manoeuvre is completed the control unit automatically switches off the ECSBus output (and all devices connected to it), the Flash output and all LEDs (with the exception of the ECSBus led, which flashes more slowly): this automatic switching off is the "Standby" function.

Subsequently, when the control unit receives a command, the normal operating mode is restored with a short delay; this function is used to reduce consumption (very important when the automation is powered by a battery)

9.7 - INSTALLING THE SOLAR POWER SYSTEM KIT model SOLEKIT

⚠ CAUTION! - When the automation mechanism is powered exclusively by the solar power supply system, **IT MUST NOT BE POWERED by the electricity grid at the same time.**

To connect the SOLEKIT solar power supply system to the control unit, see **Fig. 30** and consult the relevant instruction manual.

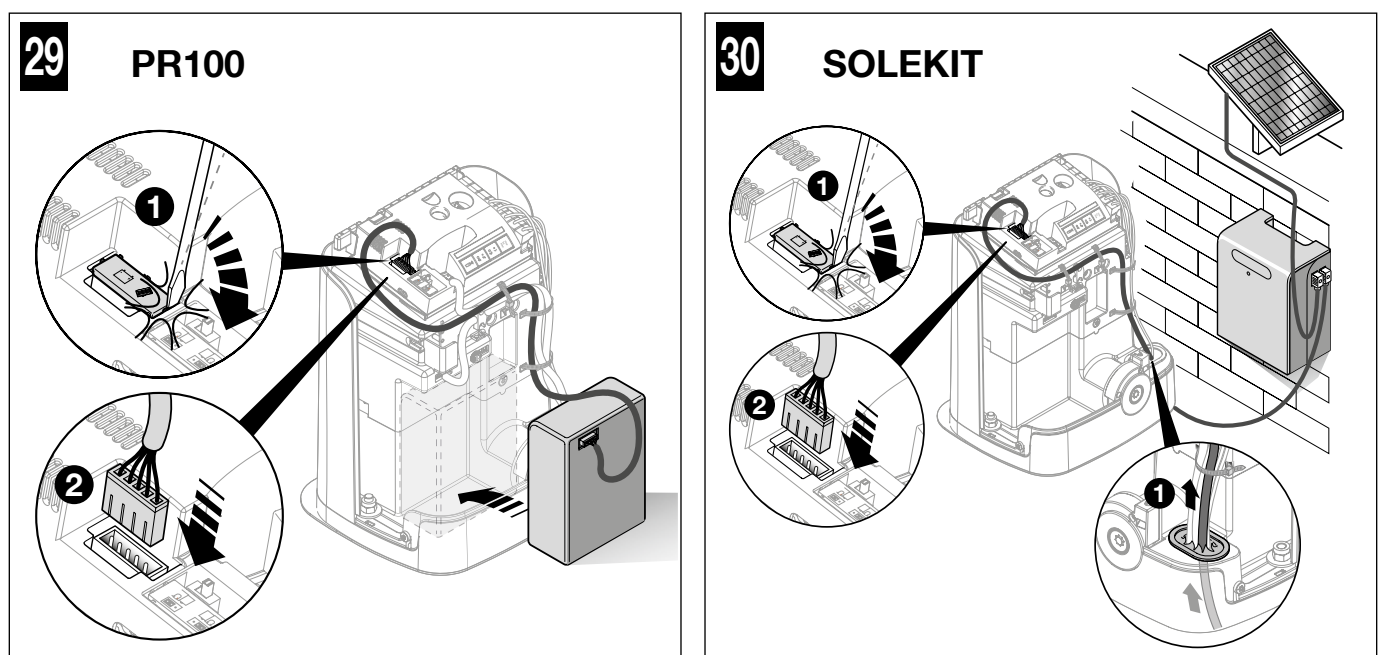

9.8 - CONNECTING THE 230 V LIGHT OUTPUT

To perform the connection see **Fig. 31** and consult the relevant instruction manual.

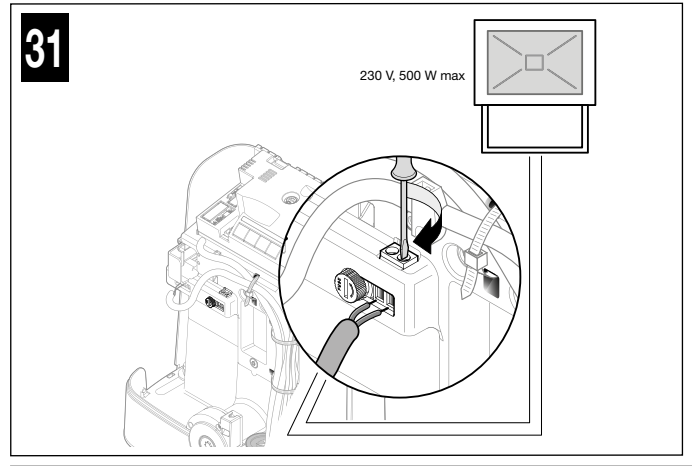

9.9 - INSTALLING THE EXTERNAL RELEASE SYSTEM model KS200KIT

To install the KS200KIT external release system in the gearmotor, see **Fig. 32** and consult the relevant instruction manual.

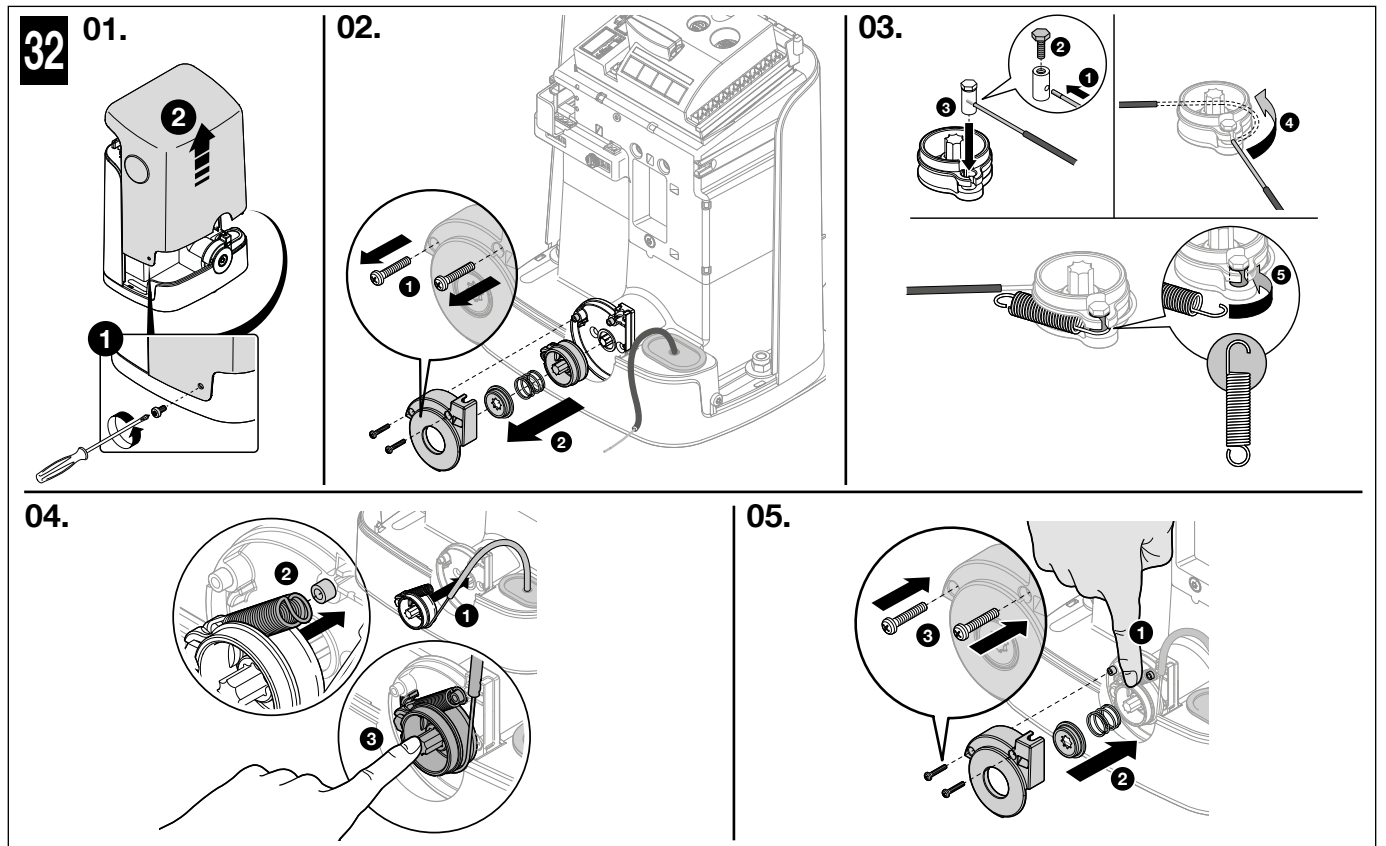

9.10 - DIAGNOSTICS AND DEVICE SIGNALS

Certain devices are configured to display messages to identify their operating status or any anomalies.

9.10.1 - Photocell signals

The photocells contain a SAFE led (**Fig. 7**) that allows for verifying their operating status at any time: see **Table 6**.

TABLE 6		
SAFE led (Fig. 7)	Status	Action
Off	The photocell is not powered or is faulty	Check that the voltage on the photocell terminals is around 8–12 VDC; if the voltage is correct, the photocell is probably faulty
3 quick flashes and 1 second pause	Device not recognised by the control unit	Repeat the recognition procedure on the control unit. Check that all pairs of photocells on the ECSBus have different addresses (consult the instruction manual of the photocells)
1 very slow flash	The RX receives an excellent signal	Normal operation
1 slow flash	The RX receives a good signal	Normal operation
1 quick flash	The RX receives a poor signal	Normal operation but check TX-RX alignment and correct cleaning of photocell lenses
1 extremely fast flash	The RX receives a bad signal	At the limit of normal operation; check TX-RX alignment and correct cleaning of photocell lenses
Always lit	The RX does not receive any signal	Check for any obstruction between TX and RX. Check that the Led on TX emits a slow flash. Check the TX-RX alignment

9.10.2 - Flashing light signals

During the manoeuvre, the flashing light emits 1 flash each second; when there is an anomaly, it flashes quickly: see **Table 7**.

TABLE 7		
Flashes (quick)	Status	Action
1 flash 1 second pause 1 flash	ECSBus error	At the beginning of the manoeuvre the devices present do not match those recognised; check and, if necessary, try running the recognition procedure (Par. 9.2.1). One or more devices may be faulty; check and, if necessary, replace them
2 flashes 1 second pause 2 flashes	Intervention of a photocell	At the start of the manoeuvre, one or more photocells do not enable movement; check to see if there are any obstructions. During the movement, if the obstacle is effectively present, no action is required
3 flashes 1 second pause 3 flashes	"Gearmotor force" limiting device activated	During the movement, the gate experienced excessive friction; identify the cause
4 flashes 1 second pause 4 flashes	Intervention of the Stop input	At the start of the manoeuvre or during the movement, the Stop input intervened; identify the cause
5 flashes 1 second pause 5 flashes	Error in the internal parameters of the electronic control unit	Wait at least 30 seconds then try giving a command; if the condition persists it means there is a serious malfunction and the electronic board must be replaced
6 flashes 1 second pause 6 flashes	The maximum manoeuvre limit per hour has been exceeded	Wait a few minutes until the manoeuvre limiting device drops below the maximum limit
7 flashes 1 second pause 7 flashes	Error in the internal electric circuits	Disconnect all the power circuits for a few seconds and then try giving a command again; if the condition persists it means there is a serious malfunction and the electronic board has to be replaced
8 flashes 1 second pause 8 flashes	A command that does not allow other commands to be executed is already present	Check the type of command that is always present (for example, it may be a command from a clock on the SbS input)
9 flashes 1 second pause 9 flashes	The automation is locked	Release the automation by sending an automation release command to the control unit

9.10.3 - Control unit signals

On the control unit there are LEDs (**Fig. 8**) that emit signals both during normal operation and in case of anomalies: see **Table 8**.

TABLE 8		
Led ECSBus	Status	Action
Off	Fault	Verify whether there is power and whether the fuses are blown; in this case, identify the reason for the failure then replace them with others of the same type
On	Serious fault	There is a serious fault; try switching off the control unit for a few seconds; if the condition persists, it means that there is a malfunction and the electronic circuit board has to be replaced
1 flash per second	All OK	Control unit works correctly
2 long flashes	Input status variation	This is normal when there is a change in one of the inputs: SbS, Stop, intervention of photocells or the radio transmitter is used
1 flash every 2 seconds	Automation in "standby" mode	All OK; when a command arrives, the control unit will restore normal operation (after a brief delay)
Series of flashes separated by a pause	Flashing light signal see Table 7	An overload has been detected therefore the power to the ECSBus was switched off. To verify, disconnect one device at a time.
Quick flash	ECSBus short-circuit	To activate power to the ECSBus, simply give a command (for example, through the transmitter)
Stop led	Status	Action
Off *	Intervention of the Stop input	Check the devices connected to the Stop input
On	All OK	Stop input active
SbS led	Status	Action
Off	All OK	OPEN input not active
On	Intervention of the SbS input	Normal only if the device connected to the SbS input is actually active
L4 led	Status	Action
Off *	All OK	No Memorisation in progress
On	Memorisation in Mode 1	During memorisation in Mode 1, it is normal for it to last maximum 10 seconds.
A series of quick flashes (from 1 to 4)	Memorisation in Mode 2	During memorisation in Mode 2, it is normal for it to last maximum 10 seconds.
5 quick flashes	Deletion OK	Successful deletion of a transmitter
1 slow flash	Incorrect command	A command has been received from a non-memorised transmitter
3 slow flashes	Memorisation OK	Memorisation completed successfully
5 slow flashes	Deletion OK	Deletion of all transmitters completed successfully

L2 led	Status	Action
Off *	All OK	"Slow" speed selected
On	All OK	"Fast" speed selected
1 flash per second	The device recognition phase has not been carried out, or there are errors in the memorised data	Perform the position recognition phase again (see Par. 5.4)
1 flash per second	Device recognition phase under way	Indicates that the search phase for connected devices is under way (it lasts a few seconds at the most)
L3 led	Status	Action
Off *	All OK	Cycle operation
On	All OK	Complete-cycle operation

* or it could be in "Standby" mode

9.11 - SPECIFICATIONS

9.11.1 - ECSBus system

ECSBus is a system that allows for connecting ECSBus devices using just two wires, which convey both electricity and communication signals. All the devices are connected in parallel on the two ECSBus wires; each device is recognised individually by the control unit, thanks to an unambiguous address assigned to each device during installation.

Photocells and other devices adopting this system can be connected to the ECSBus, such as safety devices, control buttons, indicator lights etc. For information on ECSBus devices, consult the Nice Home range product catalogue or visit the website www.niceforyou.com

Through a recognition procedure the control unit recognises one-by-one all the devices connected and this enables it to detect with extreme precision all possible anomalies during the automation's normal operation. For this reason, whenever a device connected to the ECSBus is added or removed, it is necessary to repeat the recognition procedure for these additional devices (Par. 9.2.1).

9.11.2 - Stop input

The Stop input causes the immediate stoppage and a brief inversion of the manoeuvre; both devices with normally open (NO) contacts and devices with normally closed (NC) contacts can be connected to this input, as well as devices with 8.2 kΩ constant resistance (e.g. sensitive edges). With suitable arrangements, multiple devices – even of different type – (read **Table 9**) can be connected to the Stop input.

TABLE 9				
2 nd -type device:	1 st -type device:			
	NO	NC	8.2 kΩ	
	NO	In parallel (Note 2)	(Note 1)	In parallel
	NC	(Note 1)	In series (Note 3)	In series
8.2 kΩ	In parallel	In series	(Note 4)	

Note 1: the NO and NC combination is possible by wiring the 2 contacts in parallel, while making sure that a 8.2 kΩ resistor is connected in series with the NC contact (therefore, it is also possible to combine 3 devices: NO, NC and 8.2 kΩ).

Note 2: multiple NO devices can be connected in parallel to each other without any quantity limit.

Note 3: multiple NC devices can be connected in series to each other without any quantity limit.

Note 4: only 2 devices with 8.2 kΩ constant resistance output can be connected in parallel; if required, multiple devices must be connected in "cascade" mode with a single 8.2 kΩ termination resistance.

CAUTION! – If the Stop input is used to connect devices with safety functions, only the devices with 8.2 kΩ constant resistance output guarantee Category 3 safety against faults.

Similarly to the ECSBus, the control unit recognises the type of device connected to the Stop input when the recognition procedure is carried out. Subsequently, the system triggers a STOP when any variation occurs with respect to the recognised status.

9.11.3 - Product durability

Durability is the average economic lifespan of the product. The durability value is strongly influenced by the degree of severity of the manoeuvres, in other words, the sum of all factors that contribute to product wear (Table 10). To estimate the life span of your automated device, proceed as follows:

01. Add up all the values of the entries in **Table 10**;

02. In **Graph 1**, from the value obtained above, trace a vertical line until it intersects the curve; from this point trace a horizontal line until it intersects the line of the "manoeuvre cycles". The value obtained is the estimated lifetime of your product.

TABLE 10		FILO400C	FILO600C
		Severity index	
Length of the leaf	< 3 m	0%	0%
	3 - 4 m	10%	5%
	4 - 5 m	20%	10%
	5 - 6 m	25%	15%
	6 - 7 m	-	20%
Weight of the leaf	< 200 kg	10%	0%
	200 - 300 kg	20%	10%
	300 - 400 kg	30%	20%
	400 - 600 kg	-	30%
Ambient temperature greater than 40°C or lower than 0°C, or humidity greater than 80%		20%	20%
Presence of dust, sand or salinity		15%	15%
Motor force level 4 setting		15%	15%

Note – The data refers to a sliding gate which is properly balanced and in good working order

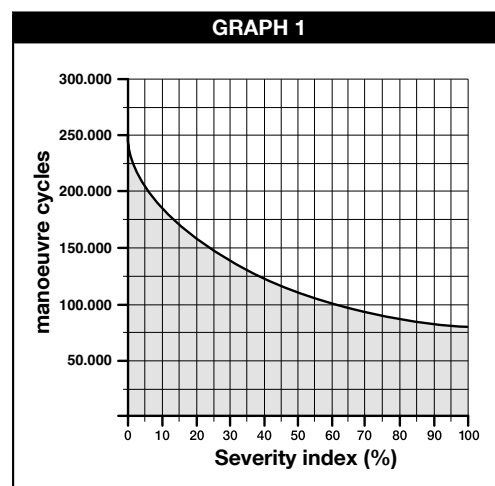

The durability values specified in the graph are only obtainable if the maintenance schedule is strictly observed (Chapter 7). The lifetime is estimated on the basis of design calculations and the results of tests performed on prototypes. Being only an estimate, it does not constitute any form of guarantee on the actual lifespan of the product.

Example of durability calculation: automation of a 3.5 m gate leaf weighing 250 kg, installed in the vicinity of the sea. Table 10 shows the “severity indices” for this type of installation: 10% (Leaf length), 20% (Leaf weight) and 15% (Presence of dust, sand or salinity). These indices must be added to each other to obtain the overall severity index, which in this case amounts to 45%. With the value found (45%), check the horizontal axis (severity index) of Graph 1 and identify the value corresponding to the number of “manoeuvre cycles” our product will be able to perform in its lifespan, equal to roughly 115,000 cycles.

10 TROUBLESHOOTING

Table 12 contains useful information to help solve any malfunctions that may occur during installation or in case of a fault.

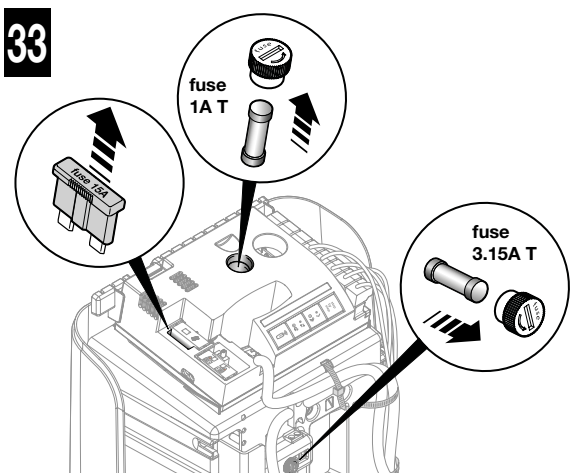
TABLE 12	
Symptoms	Probable cause and possible solution
The radio transmitter does not emit any signal and the corresponding Led fails to light up	Check the batteries: if they are flat, replace them (consult the transmitter’s instruction manual).
The manoeuvre fails to start and the ECS-Bus led on the control unit does not flash	<ul style="list-style-type: none"> • Check that the power cable is correctly inserted in the power outlet. • Check the fuses; if they have tripped, determine the cause of the fault and replace them with others of the same type: see Fig. 33. 
The manoeuvre fails to start and the automation’s flashing light is off	Check that the command is actually received. If the command reaches the SbS input, the relevant SbS Led lights up; if a transmitter is used, the ECSBus Led must emit 2 long flashes.
The manoeuvre fails to start and the automation’s flashing light emits a few flashes	<ul style="list-style-type: none"> • Check that the Stop input is active (in other words, that the Stop Led is lit). Should this not be the case, check the device connected to the Stop input. • The photocells test (which the control unit performs at the start of each manoeuvre) failed: check the photocells, by verifying their status in Table 6.
The manoeuvre starts but is immediately followed by a reverse run commanded by the control unit	The programmed “motor force” setting is too low to move the gate. Check whether there are any obstacles obstructing the gate’s movement and, if necessary, select a higher force as described in Par. 9.1.1.
The manoeuvre is carried out but the flashing light is not working	During the manoeuvre, check that there is power on the Flash terminal of the flashing light (being intermittent, the voltage value is irrelevant: roughly 10–30 VAC); if it is powered, the problem is due to the lamp not working (consult the flashing light’s instruction manual to replace it).

⚠ This user guide should be stored and handed to all users of the automation.

11.1 – WARNINGS

- Keep at a safe distance from the moving gate until it is completely open or closed; do not transit through the gate until it is completely open and has come to a standstill.
- Do not let children play near the gate or with its commands.
- Keep the transmitters away from children.
- Suspend the use of the automation immediately as soon as you notice something abnormal in the operation (noises or jolting movements); failure to follow this warning may cause serious danger and accidents.
- Do not touch moving parts.
- Regular maintenance checks must be carried out by qualified personnel according to the maintenance plan.
- Maintenance or repairs must only be carried out by qualified technical personnel.
- Send a command with the safety devices disabled:

If the safety devices do not work properly or are out of order, the gate can still be operated.

01. Command the gate with the transmitter. If the safety devices give the enable signal, the gate opens normally; otherwise, reattempt within 3 seconds and keep the control activated.

02. After approximately 2 seconds the gate will start moving in the “man present” mode, that is, so long as the control is kept activated the gate will keep moving; as soon as the control is released the gate will stop.

If the safety devices are out of order, arrange to repair the automation as soon as possible.

11.2 – Manually  releasing and locking  the gearmotor

The FILO gearmotor (model 400C/600C) is equipped with a mechanical system that allows for opening and closing the gate manually.

Manual operation must be performed in the case of a power outage or in the event of anomalies affecting the system. In case of a power outage, a back-up battery can be used (model PR100 - not supplied) (see Chapter 9 - Further information, or the relevant instruction manual).

In the event of a gearmotor fault, it is still possible to try release the motor to check whether the fault lies in the release mechanism.

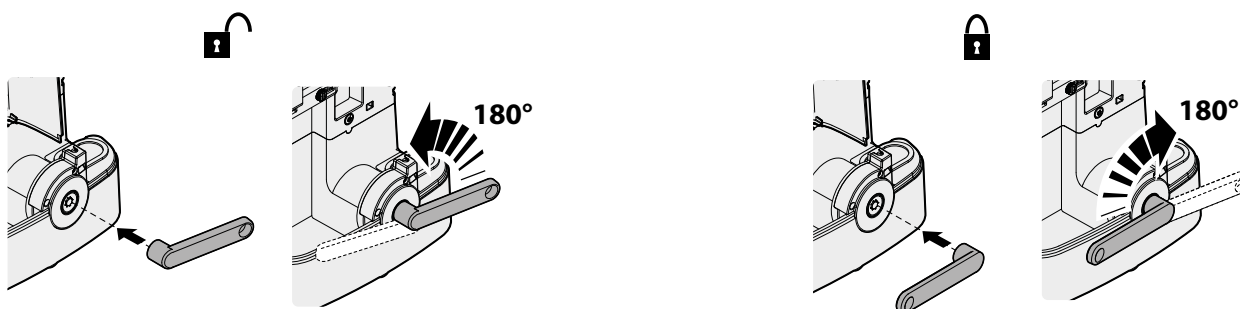

11.3 – User-admissible maintenance operations

The operations that the user must carry out periodically are listed below:

- **Cleaning of the surfaces of the devices:** use a slightly damp (not wet) cloth. Do not use substances containing alcohol, benzene, thinners or other flammable substances; the use of these substances may damage the devices and cause fires or electric shocks.
- **Removal of leaves and stones:** disconnect the power supply before proceeding, so as to prevent anyone from moving the gate. If a back-up battery is fitted, disconnect it.

11.4 – Replacing the transmitter battery

When the battery is flat, the transmitter capacity is significantly reduced. If, when a button is pressed, the relevant Led turns on then immediately fades and turns off, it means that the battery is completely flat and should be immediately replaced.

If instead the Led turns on only for a moment, it means that the battery is partially flat; the button must be kept pressed for at least half a second for the transmitter to attempt to send the command.

However, if the battery level is too low to complete the command (and possibly wait for the response), the transmitter will turn off and the relevant Led will fade. In these cases, normal transmitter operation can be restored by replacing the battery with another of the same type, while observing the relevant polarity. To replace the battery, proceed as shown below.

⚠ Batteries contain polluting substances: do not dispose of them together with common waste but use the methods set forth in the local regulations.

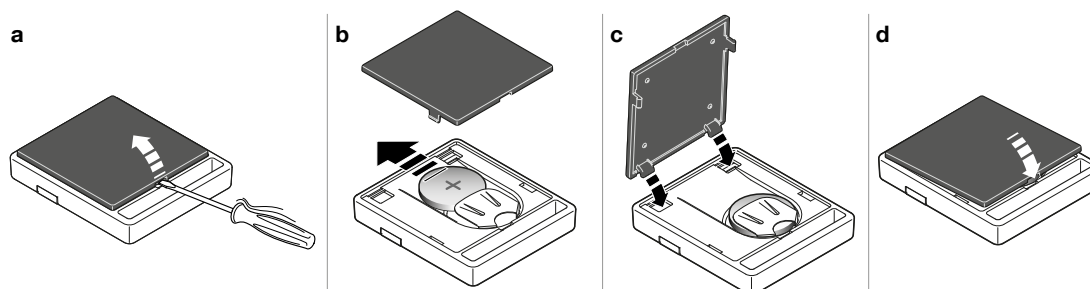

Service Après Vente France

En cas de panne, merci de contacter obligatoirement
notre Service Après Vente par téléphone ou par email :

0 820 859 203

Service 0,15 €/min + prix appel

niceservice@niceforyou.com

Merci de ne pas retourner le produit en magasin

Worldwide Customer Service

customerservice@niceforyou.com



Nice S.p.A.
Via Pezza Alta, 13
31046 Oderzo TV Italy
info@niceforyou.com

www.niceforyou.com